

**Note: this EMER (Tels L394) is currently missing pages 13, 15 and 17. Copies are being sought and will be made available as soon as they can be found.**

# The VMARS Archive

VMARS is a not-for-profit organisation specialising in all types of vintage communications electronics. We maintain an archive of documentation to help people understand, research, repair and enjoy their vintage radio equipment.

This is a gentle reminder that the document attached to this notice is provided to you **for your personal use only**. This edition remains copyright of VMARS, and you may not copy it to give or sell to other people. This includes a prohibition on placing it on websites, or printing it for sale at rallies, or hamfests.

Please refer anyone else wanting a copy back to VMARS – either to our website at <http://www.vmars.org.uk/> or by email to the Archivist at [archivist@vmarsmanuals.co.uk](mailto:archivist@vmarsmanuals.co.uk). If you want to know more about our copyright, please see the FAQ below.

## FAQ on copyright of VMARS documents

- Q** How can you copyright a document that is already in the public domain?
- A.** *Plainly the original copyright of the content has expired, or we have obtained permission to copy them. What we copyright is our own edition of the document.*
- Q.** Surely your “own edition” is identical to the original document, so cannot be copyrighted?
- A.** *Our editions are **not** identical to the original document. You will find that full advantage has been taken of electronic publishing facilities, so pages are cleaned up where possible (rendering them better than originals in some cases!), and large diagrams are prepared for both on-screen viewing and for easy printing at A4 format.*
- Q.** Why do you not just give your manuals away, as so many do via the internet these days?
- A.** *We do make all our manuals available free of charge (in soft copy) to VMARS members. These members have already covered the costs of running the archive via their subscriptions. The only time members are charged for copies is when they request them on paper, in which case charges are restricted to the cost of paper, ink and postage.*

*The VMARS archive is not a “shoe-string” operation. Money is spent on computing facilities to make copies available, and on shipping original documents securely (usually costing several pounds per shipment) to carry out the scanning. As members have already contributed to these costs, it is only reasonable that non-members should do likewise – and thus a very moderate charge is levied for copies provided to non-members. With typical commercial photocopying charges starting at 5 pence per A4 side, it will be evident that paying 4 pence for our equivalent on paper is excellent value (amounts current at Spring 2004). We also think “you get what you pay for” – we invite you to make the comparison and draw your own conclusions!*

*Despite the above, we will be making copies of essential technical information (circuit diagram, parts list, layout) freely available to all via our website from Summer 2004 onwards. This will be done to try and encourage and enable the maintenance of our remaining stock of vintage electronic equipment.*

## ***Guidance on using this electronic document***

### **Acrobat Reader version**

You need to view this document with Acrobat Reader **version 5.0** or later. It is possible that the document might open with an earlier version of the Acrobat Reader (thus allowing you to get this far!), but is also likely that some pages will not be shown correctly. You can upgrade your Acrobat Reader by direct download from the internet at <http://www.adobe.com/products/acrobat/readermain.html> or going to <http://www.adobe.com/> and navigating from there.

### **Bookmarks**

This document has had “bookmarks” added. These allow you to quickly move to particular parts of the document, a numbered section or maybe the circuit diagrams for instance, merely by clicking on the page title. Click on the “Bookmarks” tab on the left hand side of the Acrobat Viewer window to access this feature – move the cursor over these titles and notice it change shape as you do so. Click on any of these titles to move to that page.

### **Large diagrams**

The large diagrams are given in two formats – in A4 size sheets to allow easy printing, and complete as originally published to allow easy on-screen viewing. These versions are in different sections of the document, which can be found within the bookmarks.

### **Printing the document on an A4 format printer**

The document has been optimised for printing on A4 size paper (this is the common size available in UK and Europe, which measures 29.7cm by 21.0cm). Please follow these steps (these are based on Acrobat Reader version 6.0 – other versions may differ in detail):

1. Work out the page numbers you want to print. If you want to print the whole document, then within “Bookmarks” (see above), first click on “**Front**”, and note the page number given at the bottom of the Acrobat window – this will give you the page number of the first page to be printed. Similarly click on “**End of A4 printable copy**”, to determine the last page to be printed.
2. Select “File – Print” or click on the printer icon. This will bring up the print dialog box.
3. Select the correct printer if necessary.
4. In the area marked “Print Range” click on the radio button marked “Pages from..”, then enter the first and last page numbers worked out in step 1 into the “from” and “to” boxes.
5. In the “Page Handling” area, next to “Page Scaling”, select “Fit to paper”. Then press “OK”

### **Printing the document on an US Letter format printer**

Since A4 and US Letter sizes are similar, it is expected that this document should print satisfactorily on the latter format paper. This has not been tested however, and is not guaranteed. Follow the steps as for A4 printing, and make doubly sure that “Fit to paper” is selected (step 5).

### **Any other problems?**

Please get in touch with me at [archivist@vmarsmanuals.co.uk](mailto:archivist@vmarsmanuals.co.uk).

*Richard Hankins, VMARS Archivist, Spring 2004*

## FIRST AID IN CASE OF ELECTRIC SHOCK

### EXHALED AIR METHOD

1. **SWITCH OFF.** If this is not possible, **PROTECT YOURSELF** with dry insulating material and pull the victim clear of the conductor.  
**DON'T TOUCH THE VICTIM WITH YOUR BARE HANDS** until he is clear of the conductor, but **DON'T WASTE TIME.**
- 2.(a) Lay the patient on his back. Quickly loosen waist band and clothing round neck. If his mouth is open, sweep a finger through his mouth to clear obstruction and remove loose dentures.

- (b) Lift the head and tilt the head back-wards by putting one hand underneath the neck and the other on the crown of the head.



See fig. 1



- (c) Hold the head tilted as far back as possible and lift up the jaw firmly, closing the lips. This keeps the victim's airway clear by straightening the breathing passage.

See fig. 2

- (d) Take a deep breath. Open your mouth as wide as you can. Seal your lips on the victim's cheeks around his nose. Blow air into his nose until you see the chest rise (inspiration).



See fig. 3



- (e) Remove your mouth to let him breathe out, his chest will fall (expiration).

See fig. 4

- (f) Take another deep breath and blow again as soon as he has exhaled, and continue inflations 10 — 15 times a minute. (This is a little slower than the normal rate of 18).

The movement of the victim's chest provides visual confirmation of the success of your efforts.

3. If you fail with the nasal route, try the mouth as follows :-  
Lift the jaw and hold his mouth open slightly as you blow, keeping the head tilted well back with the other hand.  
Seal your lips around his opened mouth and press your cheek against his nostrils to stop air leakage, and blow until you see the chest rise.

Continue as described in (e) and (f) above until normal breathing returns or medical assistance becomes available.

#### DO NOT GIVE LIQUIDS UNTIL VICTIM IS CONSCIOUS

NOTE

If after 5 or 6 effective inflations of the patient's lungs there is :-

- (i) no improvement in the colour of the face and lips
- (ii) no constriction of the dilated pupils
- (iii) no pulse to be felt in the neck or elsewhere,  
this means that the heart is not beating.

Carry out External Cardiac Massage

## EXTERNAL CARDIAC MASSAGE

1. (a) Lay the victim on his back on the ground or on some other firm surface.
- (b) Place the heel of one hand, with the other on top of it, on the lower part of the sternum (breast bone) in the mid line of the chest, see note 1. below.
- (c) Apply firm pressure vertically downwards aided by the weight of the body, about 60 times a minute.
- (d) At the end of each pressure stroke, the hands are to be lifted slightly to allow full recoil of the victim's chest.
- (e) Sufficient pressure should be used to depress the sternum an inch or so towards the vertebral column (spine).



2. Artificial respiration must continue simultaneously with external cardiac massage at the rate of about 5 compressions of the heart to one inflation of the lungs.
3. Massage should continue until the victim's pulse is clearly felt and the colour returns to normal, or until medical assistance arrives.

### **Notes :**

1. Do not attempt cardiac massage if there is obvious damage to the victim's chest wall.
2. There is a real danger of damage to internal organs by the improper use of external cardiac massage.
3. Particular care must be taken with infants and small children, with whom much less pressure is required to depress the sternum than in the case of adults. In these cases the fingers should be used in preference to the palms of the hands.

STATION KIT, RADIO, AMPLIFIER, R.F. NO 7

(Power supply, rotary No 47 and Loading coil assembly aerial)

TECHNICAL HANDBOOK - FIELD AND BASE REPAIRS

Errata

Note: This Issue 2, Pages 0-01, supersedes Issue 1, Pages 0-03. This Issue contains additional information at items marked ●.

1. The following amendments are to be made to the regulation.
2. Page 5. Cross page heading,
  - a. Delete: '(MAIN CENTRE HEADING)'
- 3. Page 11, below Table 1  
Insert: 'Note: All voltages quoted in Table 1 are 'off load'.'
- 4. Page 14. Table 3,
  - a. Column 2, last line,  
Delete: '7.0'  
Insert: '5.0'
  - b. Column 5, last line,  
Delete: '190'  
Insert: '150'
  - c. Column 6, last line,  
Delete: '50'  
Insert: '35'
- 5. Page 15. Table 4, last line, column 2,  
Delete: '100'  
Insert: '75'
6. Page 17.
  - a. Para 45.b. line 1,  
Delete: 'o/c and s/c,'  
Insert: 'O/C and S/C,'
  - b. After Table 6, Note:  
Delete: 'FB' in line 2, and 'FC' in line 3  
Insert: 'F<sub>B</sub>' in line 2, and 'F<sub>C</sub>' in line 3

7. Page 20, Table 9.

After: last item,

Insert: ' 

12	6-12	7	60	210	150	50
----	------	---	----	-----	-----	----

 '

8. Page 21.

a. Para 53.b. and d. line 1,

Delete: 's/c' and 'o/c'  
Insert: 'S/C' and 'O/C'

b. Para 53.e.

Delete: '54.c.'  
Insert: '53.c.'

9. Page 23. Para 55.f.

Delete: '56.e.'  
Insert: '55.d.'

10. Page 24.

From 'Note: If C3 comes to a minimum ..... ' to the end of page 24 delete in entirety.

11. Page 35 and 37, para 93, 94 and 101 headings,

Delete: '(A)'  
Insert: '(B) (Base workshops only)'

12. Page 36.

a. Para 98, heading, after '(B)'

Insert: '(Base workshops only)'

b. Para 99, heading,

Delete: '(B)'  
Insert: '(A)'

13. Page 1001, Table 4001,

Add: as footnote:- 'Items 2, 12, 13 and 14 are for Base workshop use only.'

EME/8/2834/Tels

Errata

Note: This Page 02, Issue 1, must be filed immediately in front of Page 1, Issue 1 dated 1 May 1968.

(The following amendments must be made to the regulation)

10. Page 24

From 'Note: If C3 comes to a minimum .....' to end of page 24 delete in entirety.

11. Insert new page 24A attached.

T/62335/9  
EME/8/2584/Tels





The information given in this document is not to be communicated, either directly or indirectly, to the Press or to any person not authorized to receive it.

CONDITIONS OF RELEASE

(Applicable to copies supplied with Ministry of Defence approval to Commonwealth and Foreign Governments)

1. This document contains classified UK information.
2. This information is disclosed only for official use by the recipient Government and (if so agreed by HM Government) such of its contractors, under seal of secrecy, as may be engaged on a defence project. Disclosure or release to any other Government, national of another country, any unauthorized person, the Press, or in any other way would be a breach of the conditions under which the document is issued.
3. This information is to be safeguarded under rules designed to give the same standard of security as those maintained by HM Government in the UK.

STATION KIT, RADIO, AMPLIFIER, RF No 7

(Power Supply, Rotary No 47 and Loading Coil Asscnbly, Aerial)

TECHNICAL HANDBOOK - FIELD AND BASE REPAIRS

This EMER must be read in conjunction with Tels L 392 Part 2 which contains figures and tables to which reference is made.

SUBJECT INDEX

	<u>Para</u>
INTRODUCTION .....	1
INSTRUCTIONS FOR DRYING AND SEALING .....	3
AMPLIFIER RF NO 7	
MECHANICAL REPAIRS AND REPLACEMENTS	
Removal from case .....	12
Removal of front panel .....	13
To remove the valve block complete .....	14
To remove a p.a. valve .....	15
To remove anode coil and switch assembly .....	16
To open overload chassis .....	17

	<u>Para</u>
To remove grid coil and switch assembly ... ..	18
To remove vacuum tuning capacitor ... ..	19
To remove fan motor assembly ... ..	21
To remove inductuncor complete with fan assembly ... ..	22
To remove bracket holding RLE ... ..	23
To remove AE TUNE or PA TUNE dial drive assembly, or dial window ... ..	24
To replace fan motor or items in fan assembly ... ..	25
<b>SPECIFICATION TESTS TO AMPLIFIER RF No 7</b>	
General ... ..	26
Caution ... ..	28
Conditions of test	
Supply and drive ... ..	32
Tuning and matching ... ..	36
Lights and fan motor ... ..	38
Class A tests	
RF power output and efficiency with 70Ω load ... ..	39
PA tuning meter ... ..	40
PA tuning scale ... ..	41
Switching ... ..	42
Overload cut-out ... ..	43
Power consumption ... ..	44
Aerial tuning and match control coverage ... ..	45
Amplifier output ... ..	46
Overall efficiency ... ..	47
Aerial tuning scale ... ..	48
Loading coil switch control ... ..	49
Extra high voltage test ... ..	50
Class B tests	
RF power output and efficiency ... ..	51
PA tuning meter ... ..	52
Low level efficiency ... ..	53
Amplifier output and efficiency ... ..	54
Fan motor, interference with receiver ... ..	55
CW operation ... ..	56
<b>ELECTRICAL ADJUSTMENTS AND ALIGNMENT</b>	
General ... ..	57
RF alignment ... ..	59
Overload cut-out adjustment ... ..	60
<b>POWER SUPPLY, ROTARY, No 47</b>	
<b>MECHANICAL REPAIRS AND REPLACEMENTS</b>	
Instructions for drying and sealing ... ..	61
Removal from case ... ..	62
Removal of air filter ... ..	63
Cleaning the air filter ... ..	64
Removal of air filter frame ... ..	65
To remove the rotary transformer ... ..	66
Servicing the rotary transformer ... ..	67
Rotary transformer 500 hour check ... ..	68
Rotary transformer 1500 hour servicing ... ..	69
Brushes ... ..	70

	<u>Para</u>
Bearings ... ..	71
Replacement armature assembly ... ..	72
SPECIFICATION TESTS TO PSR No 47	
General ... ..	73
Standard test conditions ... ..	74
Preliminary checks ... ..	75
Output voltages on load ... ..	76
Output voltages off load ... ..	77
Ripple voltage ... ..	78
Input current ... ..	79
Ancillary circuits ... ..	80
High resistance supply ... ..	81
Overload circuit breaker ... ..	82
Continuity test ... ..	83
Extra high voltage test ... ..	84

## LOADING COIL ASSEMBLY, AERIAL

## MECHANICAL REPAIRS AND REPLACEMENTS

Instructions for drying and sealing ... ..	85
Removal from case ... ..	86
Removal of switch unit ... ..	87
Servicing the switch unit ... ..	88
To replace SC switch contacts or the limit switches SA/SB ... ..	89
Aerial loading coil ... ..	90
SPECIFICATION TESTS TO LOADING COIL ASSEMBLY, AERIAL	
General ... ..	91
Standard test conditions ... ..	92
Loading coil tests	
Inductance (A) ... ..	93
Q value and self capacitance (A) ... ..	94
Switch unit tests	
Switch operation (A) ... ..	95
Extra high voltage operation (A) ... ..	96
Current handling capacity (A) ... ..	97
Voltage breakdown (B) ... ..	98
Insulation resistance (B) ... ..	99
Functional (B) ... ..	100
Switch capacity B (A) ... ..	101

## INDEX TO FIGURES

<u>Fig</u>	<u>Page</u>
4001 Test equipment connections used with Amplifier, RF, No 7 ... ..	1004
4002 Connections used with low power dummy aerial ... ..	1005
4003 Aerial coil minimum inductance test ... ..	1005
4004 Connections for PSR No 47 tests ... ..	1006
4005 Loading coil switch tests ... ..	1007
4006 Fan motor interference with receiver ... ..	1007

INDEX TO TABLES

<u>Table</u>		<u>Page</u>
AMPLIFIER, RF No 7		
1	Standard test conditions ... ..	11
2	Lights and fan motor operation ... ..	13
3	Limits for NORMAL supply and drive conditions ... ..	14
4	Limits under LOW power supply and drive conditions ... ..	15
5	Maximum currents ... ..	16
6	Matching coverage ... ..	17
7	Amplifier output and efficiency ... ..	18
8	Loading coil switch control ... ..	19
9	Limits for NORMAL supply and drive conditions (B) ... ..	20
10	Limits under LOW power supply and drive conditions (B) ... ..	20
11	Aerial matching, low level efficiency (B) ... ..	21
12	Amplifier output and efficiency (B) ... ..	22
POWER SUPPLY, ROTARY, No 47		
13	Loads voltages and currents ... ..	30
14	Output voltages ... ..	31
15	On load input current ... ..	32
4001	Test equipment schedule ... ..	1001
4002	Test kit equipment schedule ... ..	1002

INTRODUCTION

1. The information in this regulation covers the inspection and repair of the Amplifier, r.f. No 7, the Power supply rotary No 47 and the Loading coil assembly, aerial.
2. These units, when connected together in the appropriate harness, form a complete Amplifier r.f. No 7. The designations of the three items concerned are:-
 

Section 1 - Amplifier r.f. No 7	-	5820-99-949-2150
Section 2 - Power supply, rotary No 47	-	5820-99-949-2152
Section 3 - Loading coil assembly, aerial	-	5820-99-949-3231

INSTRUCTIONS FOR DRYING AND SEALING

3. On receipt for repair the amplifier should be pressurized to 5 lb/sq in. using the Apparatus, seal testing, and a dip test carried out in a water tank to check for pin holes in the castings and also to check spindle seals and gaskets etc. As the leak specification for the amplifier must not exceed 50 C<sup>3</sup>/h, this inspection should be carried out thoroughly with the amplifier immersed for at least five minutes. The addition of a small quantity of wetting agent to the water is recommended.

4. The amplifier should be opened and repaired in the driest possible conditions, and all obvious mechanical repairs, component replacements and mechanical adjustments carried out.
5. The amplifier (removed from case) will then be placed in the Oven, drying, tels and dried for at least two hours at  $50^{\circ}\text{C}$  with dry air from the pump unit passing through the oven. (Tels M 600-9 gives full details of the Oven).
6. After cooling, the amplifier should be electrically tested and any necessary realignment or repairs carried out.
7. As soon as possible after these tests, the amplifier should be fitted with new desiccators and resealed into its case. The sealing gasket should be smeared with grease XG271 Catalogue No 9150-99-910-0511.
8. Dry air from the Oven should now be passed through the amplifier for fifteen to thirty minutes.
9. The amplifier should now be disconnected from the oven and one hole fitted with its plug and the other hole used for connecting the Apparatus, seal testing, and pressurized to  $5\text{ lb/in}^2$  using the Apparatus, seal testing and dry air from the oven. After a period of 18 hours, the pressure must not have dropped below  $4.5\text{ lb}$  (after carrying out temperature correction as laid down in Tels M 631).
10. Finally fit the other seal plug and check operation of amplifier.
11. The instructions in paragraphs 4 to 14 also apply to the p.s.r. No 47 and the sealed switch unit of the loading coil assembly, except that the leakage rate of the p.s.r. No 47 is  $20\text{ c}^3/\text{h}$  with a time constant of not less than 180 h, and the leakage rate of the loading coil is  $10\text{ c}^3/\text{h}$  with a time constant of 180 h.

AMPLIFIER R.F. No 7 (~~MAIN CENTRE HEADING~~)

MECHANICAL REPAIRS AND REPLACEMENTS

Removal from case

12. To remove the amplifier from its case use the following procedure:-
  - a. Remove the six allen-headed screws that hold the valve block to the r.h. side of the case. Carefully retain the dowty seals and O rings.
  - b. Remove the ten allen-headed screws located around the edge of the front panel.
  - c. Remove the case.

Removal of front panel

13. a. Undo the two 6BA nuts holding PLD in position and remove the plug.
  - b. Unsolder the HV co-axial lead from PLB.
  - c. Unsolder the co-axial lead from PLF.

- d. Unsolder the innors of the two co-axial leads from RLC, and the outers of this pair from the earth tags on PLC.
- e. Rotate AE TUNE and PA TUNE controls fully clockwise and lock both controls, also set FINE MATCH to 0.
- f. Remove panel light cover.
- g. Loosen the two allen-headed screws on the MC/S (SA) coupling bush and slide bush off the spindle towards the front panel.
- h. Remove the four allen-headed screws holding the guard rails.
- j. Remove the four large allen-headed screws holding front panel to web.

To remove the valve block complete

14. a. Remove anode caps.
- b. Remove earth braid from the chassis tag located between C10 and C11.
- c. Unsolder spill terminated wires on valve chassis cableform.
- d. Unsolder grid drive wire from R3.
- e. Uncouple the three suspension springs and remove valve block.

To remove a p.a. valve

15. a. Remove anode caps.
- b. Uncouple the two top support springs and tilt anode block outwards (if block is still fitted in amplifier).
- c. Remove the retaining ring holding the heat conducting springs (2 x 6BA) from the valve concerned.
- d. Remove the four heat conducting springs between the anode block and the valve.
- e. Remove the valve.

To remove anode coil and switch assembly

16. This operation is necessary to replace any of the anode coils, the anode switch or C9.
  - a. There are six 4BA screws holding the hinged plate of the overload chassis, these must be removed to allow this plate to be swung open.
  - b. Loosen the two allen-headed screws at the front end of the anode switch (SA) spindle and slide the coupling bush back.
  - c. Remove the clamp from the vacuum capacitor (C12).
  - d. Unsolder the lead from R4.

- e. Unsolder the co-axial lead from C13.
- f. Unsolder the p.t.f.e. high voltage lead and slide clear of nylon clamp.
- g. Remove p.a. valve caps.
- h. Unsolder earth braid from C9a and b.
- j. Remove the five allen-headed screws from coil assembly base plate, and then remove the coil and switch assembly.

To open overload chassis

17. Remove the six 4BA screws and unhinge the overload plate, this will give access to all items behind the panel.

To remove grid coil and switch assembly

18. This operation is necessary when replacing grid tuning capacitor or grid coil switch sections, C16 and L9.

- a. If the front panel is on, remove the MC/S switch-operating-lever bush (two allen-headed screws) and the co-axial lead between RLC and the grid coil assembly.
- b. When the front panel is off, undo the coupling bush between the anode and grid switch sections.
- c. Remove the two 6BA screws holding the coil and trimmer screen to the transverse screen (this is the screen between the anode and grid coils).
- d. Remove the two 4BA screws holding the transverse screen and slide the screen away from the earthing contacts on the web.
- e. Unsolder the three spill ended wires joined to the top left hand side of the grid coil switch front wafer.
- f. Unsolder the grid drive lead from R3.
- g. Remove three allen-headed and one hexagon headed screw (4BA side spanner required) from the plate holding the grid assembly to the web casting and remove the assembly.

Note:- Grid tracking procedure must be carried out on re-assembly of grid unit (para 58).

To remove vacuum tuning capacitor

19. a. Remove valve block and hinge open the overload chassis.
- b. Remove clamp from live end of capacitor.
- c. Remove nylon clamp holding the 4-way cableform to capacitor mounting bracket (one 6BA screw).



- d. Remove the four 2BA screws holding capacitor mounting bracket to web and withdraw capacitor plus mounting bracket to the rear and clear of the amplifier.
- e. The capacitor can now be dismantled from its mounting bracket by removing the six 4BA screws. The drive pinion is held by two allen-headed screws.

Note: When engaging drive gears, on re-assembly, the grid and anode capacitors should both be set to minimum capacity and the drive mechanism set fully clockwise. Ensure that the drive stop limits the anode capacitor travel at both maximum and minimum capacity. Grid tracking procedure must be carried out after assembly (para 58).

To remove match plate

- 20. a. If front panel is on, remove the co-axial lead from PLF and turn FINE MATCH fully clockwise.
- b. Identify and remove nine cableform leads from the tag board on the match plate.
- c. Remove the r.f. lead between the stand off insulator and inductuner (L15) brush.
- d. Release inductuner spindle clamp (allen-headed screw).
- e. It is necessary to slide the inductuner assembly to the rear (ie far enough for the inductuner spindle to clear the match plate assembly). To do this proceed as follows:-
  - (1) Unsolder the lead between the COARSE MATCH switch and front slip ring of inductuner.
  - (2) Remove the three 4BA countersunk screws holding the fibreglass plate to the centre web.
  - (3) Remove the two 4BA cheese head screws holding the brackets on the fibreglass plate to the guard rail.
  - (4) Loosen the two 2BA screws on the front brackets of the inductuner (1 cheesehead and 1 hexagon head).
  - (5) Remove the two 2BA cheese head screws from the brackets at the rear of the inductuner and draw the inductuner back far enough for its spindle to clear the match unit plate.
- f. Unsolder the coax lead running from the match unit to RLD.
- g. Loosen the two 2BA allen-headed screws (with large clamp washers) holding the match plate to the centre web.
- h. Remove the two 2BA cheese head screws from the stand-off pillars located on the outer edge of the match unit plate and carefully slide out the match plate assembly.

To remove fan motor assembly

21. a. Unsolder earth braids and wires from fan motor case to main chassis.
- b. Unsolder the two motor supply leads (spill ends) on stand-off insulator adjacent to C13 (observe colour coding).
- c. Remove the two long 6BA screws from the circular clamps holding the fan assembly to the inductunor frame; release clamps and withdraw fan assembly.

To remove inductunor complete with fan assembly

22. a. Proceed as in paragraph 25 a. and b.
- b. Unsolder inductunor brush lead at match unit tag board end.
- c. Unsolder lead from front slip ring of inductunor at S13 end.
- d. Remove the five 4BA screws holding the rear fibre glass strengthening plate (3 countersunk and 2 cheese head screws).
- e. Loosen spindle clamp at front of fibre glass shaft.
- f. Remove two 2BA cheese head screws from rear mounting brackets.
- g. Loosen two 2BA screws holding front inductunor brackets.
- h. Slide assembly to the rear and clear of main chassis.

To remove bracket holding RLE

23. a. Remove panel light cover plate to gain access to the four small allen-headed screws.
- b. Remove these, complete with the sealing washers and swing complete chassis and brackets out from above.

To remove AE TUNE or PA TUNE dial drive assembly, or dial window

24. a. Remove front panel.
- b. Remove drive knob and collet assembly.
- c. Remove lock lever, spindle bush nut, and washer.
- d. The dial drive assembly may now be removed by pushing the spindles back through the front panel.
- e. Removal of the drive assembly gives access to the dial window which can be removed by unscrewing eight 6BA countersunk screws holding the window clamping plate.

To replace fan motor or items in fan assembly

25. a. Remove complete fan assembly.
- b. Undo filter housing clamp and remove housing cover, the filter components are now readily accessible.
- c. Disengage spring coupling at flywheel end by carefully pulling extreme end of spring out of its locating hole in flywheel bush.
- d. Release clamp holding motor and withdraw motor complete with flywheel and split packing collar.
- e. Loosen the two 8BA lock nuts and remove the two 8BA cheese head screws holding the filter assembly plate to motor terminal housing.
- f. If the motor is to be replaced, unsolder the two motor leads and ensure that the three ferrite beads on each lead are not mislaid.
- g. If only the fan requires replacement ignore operations b. to f. and proceed as follows:-
- (1) Disengage spring coupling and remove clamp at fan end of shaft.
  - (2) Withdraw fan complete with end bearing and spindle for replacement of items as required.

SPECIFICATION TESTS TO AMPLIFIER RF No 7

General

26. The tests are divided into two classes, A and B. The A tests are essential to the correct operation of the equipment and must be carried out each time the amplifier is overhauled and/or inspected. Class B tests are marked as such and are included as a guide to the correct functioning of the amplifier and as an aid to fault finding, but need not be carried out on all occasions.

27. Table 4001 lists the equipment required to carry out the tests, and the layout of equipment is shown in Fig 4001 to 4003. These layouts assume that Test kit radio, amplifier r.f. No 7 (Z4/6625-99-106-4798) is available. Item numbers in brackets refer to the test kit, Table 4002.

Caution

28. The Simulator, radio signal (Test unit No 1) must NOT be treated as a signal generator. It is a power source which must be correctly loaded at all times and must not be left on continuously. When working in high ambient temperatures, the unit must be removed from its transit case to avoid overheating.

29. When tuning the simulator or the amplifier, the simulator SET DRIVE control must not be set past the white triangular mark on the front panel. Only adjust this control to the required test level when matching and tuning is accurate.

30. When changing the frequency range on either the amplifier or the simulator, reduce the SET DRIVE control to the white mark first, unless otherwise stated (see para 36 d.).

31. The dummy load (Test unit No 5) used with PSR No 47 must also be removed from its transit case when working in high ambient temperatures.

### Conditions of test

#### Supply and drive

32. The amplifier will be supplied either from the a.c. power supply unit (selected Base Workshops only) or from a p.s.r. No 47 running from secondary batteries float charged with the Westinghouse 50A superseder (Z4/00000-07885). In either case the levels will be adjusted to those shown in Table 1, using the meters on the Monitor supply unit (Test unit No 6) or a.c. p.s.u.

33. The r.f. drive source is provided by the Simulator, radio, (Test unit No 1), which is part of the test kit. This item simulates the transmitter section of a TRC13 and has a variable output.

Note: When tuning the simulator, or the amplifier, the simulator SET DRIVE control must NOT exceed the white triangular mark on the front panel; adjust this control when matching and tuning is accurate.

34. The power from the drive unit is adjusted to the levels shown in Table 1 by adjusting the SET DRIVE control on the simulator. To measure the drive power, disconnect the Amplifier r.f. No 7 and connect the Wattmeter h.f. No 2 (70Ω). After setting the correct drive level reconnect the Amplifier r.f. No 7.

Table 1 - Standard test conditions

	Supply or drive power		
	LOW	NORMAL	HIGH
Battery (Nominal)	21V	26V	29V
Heaters (regulated) ( $\pm 0.5V$ )	21V	22V	25V
HT ( $\pm 1\%$ )	1600V	2000V	2200V
MT ( $\pm 1\%$ )	320V	400V	440V
Frequency Mc/s			
1.5 - 6	10W	16W	25W
6.0 - 12	8W	12W	20W

NOTE: ALL VOLTAGES QUOTED IN TABLE 1 ARE "OFF LOAD"

35. At all times when the amplifier is operated out of its case the following test kit items must be fitted prior to switching on:

- a. The air duct to provide adequate cooling for the antenna coil. (Item 4)
- b. The external heater resistor to complete the filament circuit. (Item 19)
- c. The p.a. valve block locating plate. (Item 1)
- d. The frame to which the dummy load is fitted. (Item 11)

Note: Care must be observed when operating the amplifier on full power when uncased. To prevent overheating it is recommended that a period of five minutes continuous operation be considered the safe maximum during tests.

#### Tuning and matching

36. The following procedure will be followed when tuning and matching the amplifier. On bench tests, when operating into a 70Ω load or power meter:

- a. Set the simulator unit to the required frequency and drive power observing the SET DRIVE instructions in para 33.
- b. Set the amplifier system switch to PA TUNE.
- c. Set the Mc/s switch to the required band and adjust PA TUNE until the required frequency is shown in the window.
- d. Operate the S/R switch and adjust PA TUNE for maximum on the PA TUNE meter and adjust simulator SET DRIVE as required.
- e. Set COARSE MATCH to D, FINE MATCH to 9 and AE TUNE to 44.
- f. Set system switch to RT AND CW RECEIVE.
- g. Operate the system switch and re-adjust PA TUNE slightly for maximum reading on the power meter type TF 1020A, this operation completes the aligning procedure.

If it is necessary to operate the amplifier into an antenna or dummy antenna, omit operations e. f. and g. and proceed as follows:

- h. Set COARSE MATCH and AE TUNE to the settings given for the frequency being used, on the label on the front panel of the amplifier. (If a dummy antenna is being used the figures in the row labelled 12' 1/4 TON are to be used).
- j. Set the system switch to HTRS ON and operate the S/R switch at the same time adjusting FINE MATCH and AE TUNE controls successively for a maximum reading on the simulator meter.
- k. Set system switch to RT AND CW RECEIVE and re-adjust AE TUNE and FINE MATCH for a maximum reading on the AE TUNE meter.



d. Measure the following parameters using the meters on the Monitor power supply (item 13), or, if issued, the a.c. power supply unit. In either case the tests are first carried out under NORMAL power supply and drive conditions.

- (1) Grid current - DRIVE mA.
- (2) Screen current - MT mA.
- (3) Anode current - HT mA.
- (4) RF power - As shown by wattmeter, absorption 1020A (shown as P70 in formula)

e. At any frequency, all readings will be taken with the same amplifier control settings, and all other test conditions will be identical. Calculate the anode efficiency as follows:-

$$\text{Efficiency } \% = \frac{50 \times P70}{\text{HT mA}}$$

f. Table 3 gives the limits for these measurements under NORMAL supply and drive conditions (Table 1). All limits must be met.

g. Set the equipment to LOW supply and drive conditions (Table 1) and adjust, in turn, to the frequencies shown in Table 4.

Table 3 - Limits for NORMAL supply and drive conditions

Frequency Mc/s and Band	Minimum Drive m/A	Maximum MT mA	Maximum HT mA	Minimum Power into 70Ω (P70) Watts	Minimum Efficiency %
1.5 (1.5-3)	10	60	210	190	60
3.0 (1.5-3)	10	60	210	190	60
3.0 (3-6)	9	60	210	180	50
6.0 (3-6)	9	60	210	190	50
6.0 (6-12)	7.0	60	210	180	50
12.0 (6-12)	5.0-7.0	60	210	150-190	35-50

See Page 10





Method:

- a. Use the same connections as for power output and efficiency tests with NORMAL supply and drive conditions.
- b. Tune the amplifier, in turn, to 2Mc/s and 10Mc/s and plug into the T junction (item 25) the 70Ω cut-out load (item 7) via an additional coaxial lead (item 26). This will add the cut-out load in parallel with the Wattmeter and initiate cut-out conditions as quoted in the specification.
- c. Operating the RESET switch will restore the h.t. supply to the amplifier and r.f. output should appear on the power meter. The red OVERLOAD CUT-OUT lamp will light, check this for operation as quickly as possible to avoid damage to the amplifier.
- d. Release the RESET switch and remove the additional load, operate the RESET switch momentarily, this should restore normal working conditions.

Power consumption

44. Specification: The power consumption must not be greater than shown in Table 5.

Method:

With the connections used for power output and efficiency tests and with NORMAL supply and drive conditions; note the heater current HT AMPS, anode current HT mA and screen current MT mA (Measured by item 13, or, the a.o. p.s.u.). Set the system switch in turn, to OFF, HTRS ON, RT AND CW RECEIVE, and CW TRANSMIT. The S/R switch must not be set to S and the currents must not exceed those shown in Table 5.

Table 5 - Maximum currents

System switch	Supply currents		
	Heater	Anode	Screen
OFF	NIL	NIL	NIL
HTRS ON	4A	NIL	NIL
RT AND CW RECEIVE	4.2A	NIL	NIL
CW TRANSMIT	4.2A	25 mA	NIL

Aerial tuning and match control coverage

45. Specification: The matching coverage must be within the limits shown in Table 6.



Method:

- a. Connect the high power dummy aerial  $6\Omega$  (Item 5), and  $50\text{pF}$  (Item 2) from 2-1Mc/s and  $68\text{pF}$  (Item 3) from 10-12Mc/s, to the amplifier as shown in Fig 4001.
- b. Tune and match the amplifier as described in para 36, and set the supply and drive to NORMAL. During the initial tuning and matching, use the power of the simulator, radio signal (Item 20) alone and ensure that the maximum indication on the simulator meter is not less than 2 divisions.
- c. Measure the r.f. current flowing in the  $6\Omega$  load ( $I_6$ ), at the frequencies given in Table 7, ensuring that the r.f. current is not less than the minimum shown.
- d. Measure the anode current (HT mA), at the same time note this for the efficiency calculation in the following test.
- e. It is important to make the measurements immediately after tuning and matching as prolonged periods of transmission will result in heating which may cause a reduction in power output.

Table 7 - Amplifier output and efficiency

Frequency		AC	RF current	Anode current	Minimum	Aerial tuning
Mc/s	Band	Capacitance	$I_6$ Amps min	HT mA	efficiency %	scale limits
2	1.5 to 3	50pF	3.8		25	1-5
3	1.5 to 3	50pF	4.0		29	18-23
6	3 to 6	50pF	4.6		36	33-37
10	6 to 12	50pF	4.6		41	37.5-41.5
12	6 to 12	68pF	3.9		35	40.5-43

Overall efficiency

47. Specification: The calculated figures derived from the formula

$$\text{Efficiency} = \frac{I_6^2}{\text{HT mA}} \times 300\%$$

must not be less than those given in Table 7.

Method: Using the two sets of figures measured in the amplifier output test calculate the overall efficiency with the given formula.

Aerial tuning scale

48. Specification and Method: The settings of AE TUNE, when the amplifier is adjusted for power output tests, must be within the limits quoted for aerial tuning scale limits (Table 7).

Loading coil switch control

49. Specification and Method: With the connections used for the amplifier output test, (Fig 4001), measure the d.c. potentials between pins A and B to pin C of SKTA. The potentials will depend on the position of the COARSE MATCH switch according to Table 8 with the system switch in any position.

Table 8 - Loading coil switch control

COARSE MATCH switch position	Potential between pins	
	C and A	C and B
A	0	20-30V
B C D	20-30V	0

Extra high voltage test

50. Specification: No damage is to occur when the following voltages are fed to the amplifier which will be operating normally into a dummy antenna for a period of 10 minutes, as detailed in Method.

24V heaters	27V
2000V h.t.	2400V
400V m.t.	485V (nominal)
Drive power	25W

Method: a. Use the same connections as for amplifier output test, (Fig 4001). Set drive and voltages as in the specification, tune and match to 2Mc/s.

b. By means of the S/R switch on the harness box, control the amplifier for 9 minutes with a 1 minute (RT or CW) transmit/1 minute receive sequence, then set for 1 minute to PA TUNE.

c. At the end of this, operate the amplifier with NORMAL supply and drive conditions and measure the r.f. current in the 6Ω load at 2Mc/s.

d. The measured current must be within 0.5A of the figure obtained in Table 7 (para 46).

Class B tests

RF power output and efficiency

51. Normal performance:

The power outputs and efficiency should not be less than those shown in Table 9 with NORMAL supply and drive conditions, and the power outputs not less than those shown in Table 10 under LOW supply and drive conditions.

Method:

Carry out the measurements detailed in para 39 a. to g., substituting the additional frequencies given in Tables 9 and 10, these give the limits for these measurements under NORMAL and LOW supply and drive conditions.

Table 9 - Limits for NORMAL supply and drive conditions (B)

Frequency		Minimum Drive m/A	Maximum MT m/A	Maximum HT m/A	Minimum power into 70Ω (P70) Watts	Minimum efficiency %
Mc/s	Band					
2.0	1.5-3	10	60	210	190	60
2.5	1.5-3	10	60	210	190	60
4.0	3-6	9	60	210	190	50
5.0	3-6	9	60	210	190	50
8.0	6-12	7	60	210	190	50
10.0	6-12	7	60	210	190	50
12	6-12	7	60	210	150	50

Table 10 - Limits under LOW supply and drive conditions (B)

SEE PAGE 0

Frequency		Minimum power into 70Ω (P70) Watts
Mc/s	Band	
2.0	1.5-3	110
2.5	1.5-3	110
4.0	3-6	110
5.0	3-6	110
8.0	3-6	100
10.0	3-6	100

PA tuning meter

52. Normal performance and Method:

Carry out the tests to the specification detailed in para 40 at the following additional frequencies:-

LOW drive and supply at 1.5Mc/s (low band)  
3.0Mc/s (mid band)

HIGH drive and supply at 6.0Mc/s (mid band)  
11.0Mc/s (high band)

Low level efficiency

53. Normal performance:

The low level efficiency should be within the limits quoted in Table 11.

Method:

a. Connect the signal generator No 12, the low power dummy aerial (item No 6) and valve voltmeter VVa (TF2600), in accordance with Fig 4002.

It is very important to keep all lead lengths to a minimum and also to bond each unit to earth for this test.

b. Set S1 ~~s/c~~<sup>s/c</sup> and S2 ~~e~~<sup>e</sup>. Disconnect PLA.

c. Set the signal generator No 12, to the frequency of measurement and the attenuator to a level of 100mV. Note the reading (V<sub>1</sub>) of VVa, insert this reading in the appropriate column for reference.

d. Set S1 ~~e~~<sup>e/c</sup> and S2 ~~s/c~~<sup>s/c</sup>, connect PLA according to the frequency.

e. Adjust the MATCH and PA TUNE controls for a maximum reading on VVa, and adjust the signal generator output to produce a valve voltmeter reading (V<sub>1</sub>) as obtained in 54.c.

f. Let the attenuator reading of the signal generator be V<sub>2</sub>.

g. The measurements are to be made at the frequencies given in Table 11 and V<sub>2</sub> should not be greater than the figures quoted.

Table 11 - Aerial matching, low level efficiency (B)

Frequency Mc/s	VVa Reading (V <sub>1</sub> )	V <sub>2</sub> Max m/V
2		52
5		42
8		36
11		36

Amplifier output and efficiency

54. Additional tests as in Table 12 will be carried out as in para 46.

Table 12 - Amplifier output and efficiency (B)

Frequency		AC Capacitance	RF current I <sub>6</sub> Amps	Anode current m/A	Minimum Efficiency %
Mc/s	Band				
2.5	1.5 to 3	50pF	4.0		27
3	3-6	50pF	4.0		28
4	3-6	50pF	4.3		33
5	3-6	50pF	4.5		35
6	6-12	50pF	4.4		34
8	6-12	50pF	4.4		37
10	6-12	68pF	4.9		44

Fan motor, interference with receiver

55. Normal performance:

With a TRC13 operating as the drive source and with the amplifier switched on so that the internal fan is running. The signal: noise ratio of the TRC13 receiver must not be degraded by more than 3dB.

Method:

a. Use the same connections as used for amplifier output test with the exception that a known good TRC13 provides amplifier drive instead of item 20 (Drive unit). The C13 output will be connected to the amplifier and its a.f. output on receive to a Wattmeter absorption AF No 1 by means of a Connection box, testing, vehicle and manpack radio (as shown in Tels H 164, Fig 400 2b).

b. Tune and match the TRC13 and the amplifier to 2.1Mc/s, and switch the amplifier OFF. Remove the dummy load (item 5) from the amplifier and the 2000V HT lead from the PSR No 47.

- c. Connect a  $1/2W$   $30\Omega$  high stability resistor across the  $7.5\Omega$  terminals of the Signal generator No 12 terminating pad and a low loss  $50pF$  capacitor in series with the live lead of the pad and the amplifier antenna terminal using the dummy aerial as shown in Fig 4006.
- d. Set the Signal generator No 12 attenuator to  $45\mu V$  ( $4.5\mu V$  actual) with an f.m. signal of  $400c/s$  deviation at  $1kc/s$  mod frequency. Measure the output of the C13 on the audio wattmeter, note this reading. Switch the modulation off which should reduce the a.f. output by at least  $20dB$ .
- e. Switch modulation on and set the amplifier system switch to RT AND CW RECEIVE, this will switch on the fan, (do not switch the amplifier to send during the test).
- f. Leave the fan running and measure the new signal: noise ratio, this must not be degraded by more than  $3dB$  compared with the result obtained in ~~56. a.~~  
*55 d*
- g. Repeat this test at  $3.1, 4.1, 6.1, 8.1, 10.1$  and  $11.9Mc/s$ .

#### CW operation

#### 56. Normal performance:

Using the automatic keyer set to give an equal mark/space ratio of 60 m.s. duration, the amplifier output should have marks and spaces within the limits 45 to 75 m.s. and there should be no visible pulses (viewed on an oscilloscope) indicative of key clicks.

#### Method:

- a. Using the connections shown in Fig 4001, connect an oscilloscope across the  $6\Omega$  dummy load (item 5).
- b. Tune and match the amplifier to  $9Mc/s$  and switch to CW TRANSMIT.
- c. Set the automatic keyer for an equal mark/space ratio of 60 m.s. and observe the output on the oscilloscope.

### ELECTRICAL ADJUSTMENTS AND ALIGNMENT

#### General

57. The adjustments and alignments listed under this heading should be carried out to achieve the specification figures quoted in the specification test section. The amplifier must be opened for these operations and reference for component identification should be made to Tels L 392 Part 2.

58. Alignment may be carried with power supplied either from the a.c. power supply unit (selected Base Workshops only) or from a P.S.R. No 47 running from secondary batteries float charged with the Westinghouse 50A superseder (Z4/00000-07885) and the appropriate items from the test kit connected as shown in Fig 4001. The drive source will consist of either the Simulator (item 20), or, a C13 whichever is more convenient.



WARNING:- The d.c. supply to the amplifier (2000V) is LETHAL. Valve anodes and anode tuning components are all at this potential.

RF alignment

59. a. Tune the drive source to provide at least 12W at 6.5Mc/s.
- b. Set the amplifier to:-
- (1) System switch PA TUNE.
  - (2) Band switch 6-12Mc/s
  - (3) COARSE MATCH D
  - (4) FINE MATCH 9
  - (5) AE TUNE 44
  - (6) PA TUNE 6.5Mc/s
- c. Switch the power supply on and set the l.t. volts to 24 and the h.t. to 2000V.
- d. Operate the S/R switch as required and adjust PA TUNE knob until a peak reading is obtained on the PA TUNE indicator. Adjust the slug in L3 (furthest from front panel) to give a maximum meter reading. (See Tels L 392 Part 2 Fig 2504 for component layout). Repeat adjustment of knob and slug until the maximum meter reading occurs at 6.5Mc/s as shown on the dial.
- e. Retune the drive source and amplifier to 11.5Mc/s and repeat the above using C3 trimmer (furthest from front panel) and tuning knob to give a maximum reading at 11.5Mc/s as shown on the dial.
- ~~Note: If C3 comes to a minimum and correct alignment is impossible, slacken the grub screws holding the grid capacitor (C4) worm wheel until the capacitor can just be turned by hand. Repeat the alignment procedure but replace the adjustment of C3 by adjustment of the grid capacitor. Turn the PA TUNE control to the limit (ie 12Mc/s) and ensure that the brush contact on L15 is approximately 3/4 turn from the end and that the vanes of the grid capacitor have not gone beyond minimum capacitance. Lock the grub screws and align the other bands.~~
- f. Repeat both operations, 59. d. and e. until no further improvement is obtained.
- g. Align on the mid band (3-6Mc/s) using L2 and C2 (middle location) at 3.2 and 5.75Mc/s.
- h. Align on the low band (1.5-3Mc/s) using L1 and C1 (nearest to front panel) at 1.6 and 2.85Mc/s.
- ~~j. Check after alignment that performance meets specification.~~

Note: This Page 24A, Issue 1, must be filed immediately after Page 24, Issue 1 dated May 68. It contains additional information and information previously on Page 24, Issue 1 dated May 68.

Note: If C3 is at its minimum setting (ie vanes completely unmeshed) and it is impossible to obtain satisfactory alignment at 11.5MHz, proceed as follows:-

1. Rotate PA TUNE for maximum reading on meter. Note the indicated frequency on PA tuning dial.
2. Switch off.
3. Set C3 so that vanes are in the 1/4 meshed position.
4. Rotate PA TUNE knob towards l.f. end until the grub-screw on grid-capacitor shaft is accessible (dial approx 7.5MHz).
5. Loosen this grub-screw until it protrudes by 1/8 in. approx.
6. Rotate PA TUNE dial until remaining grub-screw on grid-capacitor shaft is vertical. Lock PA TUNE knob.
7. Slacken off the grub-screw until it protrudes approx 1/8 in.
8. Using the shaft extension at rear of grid-capacitor, rotate vanes by approx 5° (1/16 in.), either further into mesh if reading noted in sub-para 1 was below 11.5MHz, or out of mesh if the reading was above 11.5MHz.
9. Re-tighten the grub-screw before releasing PA TUNE locking lever.
10. Switch on and repeat alignment procedure detailed in paras 59.d. and e.
11. Repeat sub-paras 1 to 10 above if necessary.
12. When alignment is satisfactory, switch off and tighten remaining grub-screw.
13. Check that equipment is tuneable to 12MHz, and that at this frequency the grid-capacitor is not fully unmeshed, and that the brush contact on L15 is approx 3/4 turn from the end of the winding.
  - f. Repeat both operations, 59.d. and e. until no further improvement is obtained.
  - g. Align on the mid band (3-6MHz) using L2 and C2 (middle location) at 3.2 and 5.75MHz.
  - h. Align on the low band (1.5-3MHz) using L1 and C1 (nearest to front panel) at 1.6 and 2.85MHz.
  - j. Check after alignment that performance meets specification.



Overload cut-out adjustment

60. a. Connect the equipment as shown in Fig 4001 using the 70Ω load and have the 70Ω cut-out test device (item 7) ready for use.
- b. Identify RV1 and RV2 location from Tels L 392 Part 2 Fig 2503.
- c. Tune drive source and amplifier to 4Mc/s. Switch amplifier to RT AND CW RECEIVE and put the S/R switch to S.
- d. Check that Ia is approximately 160mA (when Va is set to 2000V) by means of the meters on item 13 (or the a.c. p.s.u.). Adjust PA TUNE, if necessary, to obtain 160mA ±5/o.
- e. Put the S/R switch to R.
- f. Connect the VV No 3 set to 10V d.c. (shunted with a 0.1μF capacitor) across the combination of MR2 and RLB in series (ie from RV1 tip to RV2 tip).
- g. Put the S/R switch to S and adjust RV1 and RV2 so that the meter reading is 0 volts with the normal 70Ω load and 4V with the two 70Ω loads in parallel (ie connect item 7 for the second test).
- h. Carry out the cut-out specification test after adjustments.

POWER SUPPLY, ROTARY, NO 47

MECHANICAL REPAIRS AND REPLACEMENTS

Instructions for drying and sealing

61. Follow the instructions detailed in para 3 to 11, substituting 'p.s.r. No 47' for 'amplifier' where necessary.

Removal from case

62. To remove the p.s.r. from its case, undo the six allen headed screws located around the edge of the front panel. Removal of the p.s.r. will give access to the main assembly and also the air filter. (See Tels L 392 Part 2, Fig 2509 for component layout).

Removal of air filter

63. The filter is held by four screws to a frame inside the case. Remove these screws and lift the filter clear. Examine the two rubber gaskets and renew if necessary on re-assembly.

Gasket Part Nos	5820-99-102-6493 (Ring gasket)
	5820-99-102-6470 (Flat gasket)
Filter element Part No	4130-99-102-6434

Cleaning the air filter

64. The air filter is impregnated with grease XG271 (9150-99-910-0511) to trap particles of carbon, which otherwise would float around in the air stream (caused by the cooling fan on the rotary transformer) and cause h.t. breakdown, especially on the 2kV line. The filter must be removed, cleaned and reimpregnated after the first 500 hours of running or at the end of the first year's running, whichever is the sooner. Subsequent cleaning will then only be necessary after running times of 1500 hours, unless a replacement rotary is fitted before this; in this case revert to a 500 hour running period for the first clean. To service the filter element proceed as follows:-

- a. Clean away any loose carbon dust from the element, and the frame left inside the case.
- b. Thoroughly degrease the element with a suitable solvent, such as benzine.
- c. Finally clean the element again in a hot detergent solution, dry thoroughly and verify that the element is clean.
- d. Prepare a mixture of equal parts of grease XG271 and benzine (2 oz. of grease per element).
- e. Apply the mixture evenly to one side of the element and lightly tap the element until the mixture reaches the other side.
- f. Allow sufficient time for the benzine to evaporate, leaving a film of undiluted grease over the mesh. The deposit at the end of impregnation should be between 1.1/4 and 1.3/4 oz. of grease.
- g. Refit the element into the case and ensure that it will be in correct alignment with the end of the rotary transformer.
- h. Before refitting the main assembly into the case, thoroughly clean off any deposits of carbon dust that may have collected, especially around high potential points, eg the 2kV h.t. plug and the stand-off insulators in the h.t. line, also around brush caps.

Removal of air filter frame  
(Normally base repairs only)

65. After removal of the air filter, the frame can be removed from the case. Proceed as follows:-

- a. Mark both case and frame for future identification (if they are to be kept together on re-assembly).
- b. Loosen the four 2BA lock nuts, one in each corner, then loosen the holding screws with an allen socket wrench and withdraw the frame.

c. When the frame is removed four set screws will be found in the lower face, these are sealed with red locking paint and should not be disturbed unless the frame is to be fitted in another case. If this is so, on re-assembly, re-set the screws so that the distance between the top of the frame (ignore the gasket) and the top ground face of the case is between 10.3 to 10.32 in. Reseal the screws after adjustment.

To remove the rotary transformer

66. a. Remove the rotary transformer fly lead connections, (refer to Tels L 392 Part 2 Fig 2519 for lead identification).
- b. Loosen the four ZBA nuts on the hinged tie rods used to hold the two halves of the clamp castings.
- c. Loosen the four 7/16 in. AF nuts holding the clamps to the rear of the front panel. Use a cranked ring spanner and take care to avoid damage to the circuit breaker and the heater fuse mountings.
- d. Ease the clamps apart and withdraw the rotary transformer from its mounting.

Servicing the rotary transformer

67. The rotary transformer will be inspected after the first 500 hours of running and serviced at subsequent 1500 hour running periods, unless a new armature or complete rotary transformer is fitted into the p.s.r. If so, revert to a 500 hour period for the next inspection.

Rotary transformer 500 hour check

68. This is confined to cleaning away carbon dust and an inspection of the wear state of the input circuit brushes. These are mounted in 2 pair assemblies complete with tensator spring, they are the brushes nearest to the fan and must be replaced if worn down to 0.3 in. Access to the brush assemblies is gained by removal of the spring aperture cover at the fan end of the rotary and then removing the two cheese head screws holding the brush plate, this will release the brushes. If the brushes are worn and require replacement the tubular cover shield held by four cheese head screws will have to be removed. The new brushes must be bedded in by threading a strip of fine sandpaper between the brush and commutator following the curve of the commutator and pulling in the direction of armature rotation (clockwise looking from fan end). Two or three long pulls, lifting the brushes on each return pull should be sufficient. Final bedding will take about 20 hours of running. Long term trials revealed that h.t. brushes do not wear rapidly and it is not normally necessary to check them at this stage.

Rotary transformer 1500 hour servicing

69. After 1500 hours of running time the rotary transformer must be completely overhauled. Strip the rotary transformer using the following procedure:-
- a. Remove all brushes.
- b. Remove tubular cover shield from the input end.

- c. Remove fan (normal r.h. thread) and thrust washer under securing nut.
- d. Remove generator bearing endplate (generator end) containing steel shims and a spring steel thrust washer.
- e. Remove all brush connections

2kV connections:-                   + Red  
  - Black

400V connections:-                  + Blue  
  - Light green

Input connections:-                 + Yellow  
  - Brown

Support brush leads whilst disconnecting.

- f. Centre pop end castings and main body as a guide for reassembly, and remove stator nuts.
- g. Remove casting from generator end and carefully withdraw the armature.
- h. Remove casting from input end of body.
- j. Remove ball races from both castings, fit new races and pack with bearing grease.
- k. Check that the armature commutators are in good condition. If they are suspect, commutators can be re-turned on a vibration free lathe, using a tungsten carbide tool at 1000 r.p.m. and finally polishing with extremely fine glass paper or with a diamond tool at 1500 r.p.m. Commutator details are as follows:-

Input:-	38 Segments dia 1.603 in.	Min turning dia 1.330 in.
Output H.T.1:-	95 Segments dia 1.945 in.	Min turning dia 1.840 in.
Output H.T.2:-	95 Segments dia 1.945 in.	Min turning dia 1.840 in.
H.T.:-	97 Segments dia 1.383 in.	Min turning dia 1.312 in.

Input commutator separators are undercut 0.020 in. wide by 0.025 in. deep. All others are flush.

l. After servicing re-assemble the rotary transformer and bed in the brushes (as detailed in para 68) prior to running the machine.

m. The insulation resistance between windings and from each winding to frame must not be less than 20M $\Omega$  at 500V.

**NOTE:** When refitting the rotary transformer into its clamp, it must be clamped firmly by means of the threaded tie bars prior to tightening the casting to the front panel.

Brushes

70. The following brushes are used in the rotary transformer:-

Input (2 pairs) complete with tensator springs	- X2/5977-99-102-9315
Output HT (4 off)	- X2/5977-99-102-9755
MT (2 off)	- X2/5977-99-102-8756

The wear limit for all brushes is 0.3 in. long.

Bearings

71. One at each end of the armature spindle, both single row radial ball bearings.

Fan end 8mm diameter	- LV6/MT7/3110-99-950-0048
M.T. end 9mm diameter	- LV6/MT7/3110-99-950-0106
Bearing grease	- Type XG275 4 oz tube - 9150-99-910-0512

Replacement armature assembly

72. Armature, dynamotor slot wound, type 2.3/4 in. dia. 12.35/64 in. long, Part No X2/6125-99-102-8750.

SPECIFICATION TESTS TO P.S.R. No 47

General

73. The tests detailed in this section are all A tests and are essential to the correct functioning of the p.s.r. They must be carried out each time the power supply is overhauled and/or inspected. Table 4001 lists the equipment required to carry out the tests, and the layout of equipment is shown in Fig 4004. These tests assume that Test kit, radio, amplifier r.f. No 7 is available (24/6625-99-106-4798).

Standard test conditions

74. For all A tests the P.S.R. No 47 will be connected to the dummy load (item 8) via the Monitor power supply No 1 (item 13). The battery supply will be connected to the P.S.R. No 47 using the Monitor power supply No 2 (item 16) and the battery will be floated by means of the Item 3 Table 4001. Standard supply voltages are:-

Low	21V
Normal (off charge)	23V
Normal (on charge)	26V
High	29V

The negative lead is earthy. The nominal loads, voltages and currents are given in Table 13.



Table 13 - Loads voltages and currents

Nominal output	Connection	Load resistance ohms	Nominal current
2000V H.T.	PLB centre to SKA pin M	11,200	179mA
400V M.T.	SKA pin A to earth	4,700	50mA
23V Heaters	SKA pin C and D to earth	6.4	3.6A

Note:- The 400V m.t. supply has a source resistance of 3.3k $\Omega$ . A potential of 400V can thus only appear inside the p.s.r. or externally under lightly loaded conditions.

Preliminary checks

75. a. Check that the fuse link in use, and the spare, is of the correct rating 7.5A.
- b. Connect the battery supply and make the main switch on the Monitor power supply No 2 (item 16). Check that the circuit breaker (CT BKR) is pressed in.

Output voltages on load

76. Specification: The on load voltages must be within the limits quoted in Table 14.

- Method:
- a. Connect the equipment as detailed for standard test conditions and as shown in Fig 4004.
- b. Switch the load switches on and run the generator for 10 minutes by operating the send/receive switch.
- c. Set the supply voltage to the levels shown in Table 14 and measure the output voltages. (The V.C.R. switch on the dummy load simulates the v.c.r. in the vehicle harness).
- d. The output voltages must be within the limits given in Table 14.

Table 14 - Output voltages

Input volts	Output volts			V.C.R. switch
	2000V h.t.	400V m.t.	Heaters	
Normal on charge 26V	1900-2100	200-250	20.5 to 22.5	O/C
Normal off charge 25V	1700-1900	195-225	21.5 to 23.5	S/C
Low 21V	1500-1700	175-205	19.5 to 21.5	S/C
High 29V	2050-2350	250-280	23 to 25	O/C

Output voltages off load

77. Specification and Method:
- a. Switch off the HT, MT and HPR loads.
  - b. With the battery supply set to HIGH (29V) the output voltages must not exceed:-

2000V h.t. - 2550V  
400V m.t. - 500V

Ripple voltage

78. Specification: The ripple voltages on 2000V h.t. line must not exceed 60V and the 400V m.t. line 20V.

- Method:
- a. Using the standard test conditions (para 74) connect the oscilloscope, in turn, to the 2000V h.t. and 400V m.t. test points on the load. (These test points have blocking capacitors between them and the h.t. points).
  - b. The peak to peak value of the ripple voltage with NORMAL (26V) supply must not exceed the specification.

Note: It is normally necessary to switch off the charger during this test to avoid spurious measurements.

Input current

79. Specification: The on load input currents will not exceed those quoted in Table 15.

- Method:
- a. Use the standard test connections and set the input supply to Normal on charge (26V).
  - b. Set the switches on the dummy load as indicated in Table 15.

Table 15 - On load input current

HT and MT load switch	HTR load switch	S/R switch	Maximum current
OFF	OFF	OFF	NIL
OFF	OFF	ON	12A
OFF	ON	OFF	3.7A
ON	ON	ON	30A

Ancillary circuits

Starting circuit

80. Specification: The input starting current must be not less than 30A and not more than 45A.

- Method:
- a. Use the standard test connections and set the input to HIGH supply (29V).
  - b. Monitor the starting current with the oscilloscope by connecting it across the input current meter shunt. (Calibrate the deflection on the oscilloscope during steady running).
  - c. Make the S/R switch momentarily and measure the input current at the moment that RLA releases, ie immediately before the current falls to zero.
  - d. The measured input current must be between 30 and 45A.

Note: To obtain a clear trace the charger must be switched off during this test.

High resistance supply

81. Specification: Under test conditions simulating a high resistance battery there must be no chattering of the starter circuit relays and the p.s.r. must start smoothly.

- Method:
- a. Use the standard test conditions and set the supply conditions to LOW (21V).
  - b. Introduce an additional 200 milliohm resistance into the battery circuit by removing the shorting link on Metering unit No 2.
  - c. Start the p.s.r. from rest three times and ensure that the specification conditions are satisfied on each run-up.

Overload circuit breaker

82. a. Unscrew the plastic cover and pull out the circuit breaker button, this should prevent the p.s.r. from starting in the normal manner.
- b. The circuit breaker must not have operated during the starting circuit or high resistance supply tests.

Continuity test

83. With all supplies and loads disconnected, measure the resistance between SKA pin M to SKA pins E and F. It must be between 80 and 120k $\Omega$ .

Extra high voltage test

84. Specification and method:
- a. Using the standard test connections, set the supply voltage to 31.6V and the V.C.R. switch to O/C.
- b. Put the S/R switch to S and run the p.s.r. for ten minutes, switching the HT and MT loads on and off during alternate minutes.
- c. The p.s.r. must continue to operate under these conditions without damage.

LOADING COIL ASSEMBLY, AERIAL

MECHANICAL REPAIRS AND REPLACEMENTS

Instructions for drying and sealing

85. Follow the general details in para 3 to 11 for the sealed switch unit of this assembly, but note that the dessicator for this item is mounted inside the base which must be removed if the dessicator is to be changed.

Removal from case

86. a. Remove connecting leads between the loading coil and the fibreglass cover.
- b. Remove screws holding the cover to the base, then lift cover away from the assembly (note that the terminals on the cover are located above the loading coil on re-assembly).

Removal of switch unit

(See Tels L 392 Part 2, Fig 2507)

87. Disconnect PLA and the two leads from the insulators, remove the four nuts and bolts holding the switch casting to the tray and lift the assembly clear.

Servicing the switch unit

(See Tels L 392 Part 2, Fig 2508)

88. With the switch unit removed from the main assembly, access to the desiccator, drive motor, and the switch driving gears, is obtained by removing the base plate held by four socket headed screws. To inspect, or adjust, the r.f. switch contacts proceed as follows:-

- a. Remove the base plate.
- b. Make an alignment mark between one insulator and the case, then remove the insulator (held by a clamping ring and six cheese head screws).
- c. Rotate the worm gear on the motor shaft until S.C. rotor contact bar is located in a convenient position for inspection of contacts, these should be set between 0.25 to 0.28 in. between contact surfaces.
- d. If the contacts require replacement a new switch rotor assembly must be fitted.

To replace SC switch contacts or the limit switches SA/SB

89. a. Proceed as in para 88 a. to c.
- b. Rotate the motor worm gear until S.C. contact bar is at right angles to the drive motor shaft (ie open circuit position).
  - c. Remove SKTB and the four screws from the motor assembly plate, then withdraw the complete inner assembly.
  - d. Replace items as necessary and re-assemble.
  - e. Re-pack the insulator seal gaskets with grease XG271 (9150-99-910-0511) and the gears with grease XG275 (9150-99-910-0512).
  - f. On re-assembly ensure that the fixed contacts of SC are aligned accurately in relation to the case, and that the rotor drive bar is located correctly between the drive locating springs (Fig 2508).
  - g. Carry out specification tests to ensure correct operation.

Aerial loading coil

90. The aerial loading coil is an encapsulated assembly and as such will be replaced as a complete item if it does not meet specification.

SPECIFICATION TESTS TO LOADING COIL ASSEMBLY, AERIAL

General

91. The tests are divided into two classes, A and B. The A tests are essential to the correct operation of the equipment and should be carried out each time the loading coil assembly is overhauled and/or inspected. Class B test is marked as such and is included as a guide to the correct functioning of the assembly and as an aid to fault finding, but need not be carried out on all occasions. Table 4001

lists the equipment required to carry out the tests, and the layout of the test kit equipment is shown in Fig 4005. This layout assumes that Test kit, radio, amplifier r.f. No 7 is available (Z4/6625-99-106-4798).

### Standard test conditions

92. Testing the aerial loading coil assembly will take place in two phases,
- with the two sub-units (Loading coil and Switch unit) mounted on the tray but not wired and without the cover in position,
  - fully wired and complete with the cover fixed in position.

Tests under a. are sub-divided into loading coil tests and switch unit tests.

### Loading coil tests

Inductance (A)(R) (SAFE WORKSHOP ONLY)

93. Specification and method: The inductance of the loading coil measured on the low frequency bridge will measure between 100 and 115 $\mu$ H.

Q value and self capacitance (A)(R) (SAFE WORKSHOP ONLY)

94. Specification and method:
- Using the Q meter, resonate the loading coil at 0.75 and 1.5Mc/s. Note the indicated tuning capacity and Q values.
  - The Q value at 1.5Mc/s must not be less than 600.
  - Calculate the self capacity of the coil from the tuning capacity required at 0.75Mc/s (C1) and 1.5Mc/s (C2).
  - Self capacity (C0) =  $\frac{C1}{3} - \frac{4 \times C2}{3}$ , the self capacity must not exceed 15pF.

### Switch unit tests

Switch operation (A)

95. Specification and method:
- Connect the switch unit to the 24V supply by means of the control box (Item 23) and 3 way lead (Item 29).
  - Switch the 24V supply ON and set the control switch to A, there will be a connection between the r.f. terminals on the switch unit (SC closed).
  - Set the control switch to B, there will be no connection between the terminals on the switch unit (SC open). In each case it will be necessary to wait until the switch operating motor has stopped running before making the checks.

d. Check intermittent operation of the motor, by means of the supply switch, to ensure that the motor has no stalling position. Check 3 times on the A position and again on the B position.

Extra high voltage operation (A)

96. Repeat the whole of the previous tests a. to d. with an input of 31.6V. The switch must still operate correctly.

Current handling capacity (A)

97. Specification and method:
- a. With the switch unit in the closed position pass a current of 7A from a 6V d.c. supply through SC switch contacts, adjust the current by means of a 1 $\Omega$  rheostat.
  - b. Measure the voltage drop across the r.f. terminals with 7A flowing.
  - c. The voltage drop must not exceed 4.5mV.

Voltage breakdown (B) ~~(Paper Workshop Only)~~

98. Specification and method:
- a. With the switch unit in the closed position apply 10kV between one terminal and the case by means of the Test set, insulation. There must be no breakdown.
  - b. With the switch unit in the open position apply 10kV between one terminal and the case as before. There must be no breakdown.

Insulation resistance ~~(B)~~ (A)

99. Specification and method:
- a. Using Megohmmeter, mains, 0.05 to 200,000M $\Omega$ . Measure the insulation from one terminal to the case, with SC closed.
  - b. The insulation resistance must be greater than 500M $\Omega$ .

Functional (B)

100. Specification and method:
- a. With the loading coil assembly wired and completely assembled with the cover in position, carry out a functional test in conjunction with a fully tested Amplifier r.f. No 7.
  - b. Connect the units, tune and match using the dummy aerial H.P. (Item 5) as the load.
  - c. It will be possible to tune and match to 1.5Mc/s and F Mc/s with the COARSE MATCH in position A, and to F Mc/s and 3.0Mc/s with the COARSE MATCH in position B (F Mc/s is any one frequency in the range 1.8 to 2.2Mc/s).

Switch capacitance ~~(A)~~<sup>(B)</sup> (~~BASE WORDPHONE ONLY~~)

101. Specification and method:
- a. Using the Q Meter or if more convenient a capacity bridge, measure the capacitance between one terminal and case of the switch unit (disconnected from the loading coil) in the closed position.
  - b. The measured capacitance must not exceed 12pF.
  - c. Repeat the test with the switch open and from each terminal to case.
  - d. The measured capacitance must not exceed 5pF.

Note: The next page is Page 1001.





Table 4001 - Test Equipment Schedule

Item No	Preferred Test Equipment Stock No and Designation	Suitable Alternative
1	Z4/6625-99-106-4798 Test kit radio, Amplifier r.f. No 7. See Table 4002	
2	Z4/00000-07885 A.C. power supply unit, Amp r.f. No 7 (selected workshops only)	P.S.R. No 47 with item 3
3	Z4/6130-99-104-1932 Power supply set, rectifier 50A (Westinghouse 6252)	
4	Z4/6625-99-106-1341 Voltmeter, set, electronic (Marconi TF2600/S)	Z4/6625-99-103-3116 Voltmeter, electronic (Marconi TF2600)
5	Z4/6625-99-108-9657 Multimeter, set, electronic (Aimeco 314A/S)	Z4/6625-99-943-8384 Multimeter, electronic CT429 or Z4/6625-99-949-0470 Voltmeter valve No 3 CT208 eqpt
6	Z4/6625-99-105-7049 Multimeter, set CT498A (AVO 9SX Mk III)	Z4/6625-99-949-1999 Multimeter, set CT498 Z4/6625-99-943-1524 Multimeter, AVO, model 88 panclimatic equipment
7	Z4/6625-99-952-0551 Wattmeter, absorption (Marconi TF1020A/4M1)	
8	Z4/ZD 00747 Wattmeter, absorption, h.f. No 2 CT211 (Marconi TF957)	
9	Z4/6625-99-102-8077 Signal generator No 12/2 CT320A	Z4/ZD 02674 Signal generator No 12 CT320
10	Z4/6625-99-102-6694 Oscilloscope set, CT436, with probe (Solartron CD1014/5)	
11	Z4/6625-99-949-2062. Megohmmeter mains 0.05-200,00CMΩ	
12	Z4/6625-99-104-0284 Test set, insulation, set (Aimeco 251)	
13	Z4/6625-99-955-3163 Bridge, set, universal CT530, set	Z4/6625-99-943-2442 Bridge, universal CT375
14	Z4/6625-99-106-2685 Panel, test, electrical (C/W oscillator TF1246)	Z4/6625-99-104-6693 Q meter, set (Advance T2)
15	Z4/5820-99-103-4146 Keyer automatic, two operating speeds (Part of Z4/5820-99-103-4697 Test kit, radio SRA13).	

NOTE - ITEMS 2, 12, 13 AND 14 ARE FOR BAVE WORKSHOP ONLY

Table 4002 - Test kit equipment schedule

Item No	Designation	Catalogue No	No off	Remarks
1	ALIGNMENT JIG, brass (Test Unit 10)	Z4/6625-99-106-3530	1	Locates valve block in amp when used outside of case.
2	CAPACITOR UNIT, TEST KIT, RADIO - 50pf (Test unit No 2'o')	Z4/6625-99-106-5284	1	Alternative capacitor for dummy antenna H.P.
3	68pf (Test unit No 2'd')	Z4/6625-99-106-5285	1	Alternative capacitor for dummy antenna H.P.
4	DUCT, AIR, A1 (Test Unit No 12)	Z4/6625-99-106-3528	1	Completes air circuit when amplifier is uncased
5	DUMMY LOAD, ELECTRICAL - 6 ohms (Test unit No 2'a')	Z4/6625-99-106-4943	1	Simulates 8 ft antenna load (H.P.)
6	(Test unit No 3)	Z4/6625-99-106-3529	1	Simulates 8 ft antenna load (L.P.)
7	70 ohms, 100 watt (Test unit No 4)	Z4/6625-99-106-5283	1	Used for mismatch test
8	(Test unit No 5)	Z4/6625-99-106-4953	1	Simulates amp r.f. No 7 load, used with Monitor power supply No 1
9	including - CASE EQPT, RACK MTG, 8 unit 9 in. chassis Qty 1	Z1/5975-99-911-0538		
10	LID, Case eqpt, rack mtg, 8 unit Qty 1	Z1/5975-99-940-0542		
11	FRAMEWORK, TEST UNIT, (Test unit No 2'b')	Z4/6625-99-106-6235	1	Includes antenna base.
12	INTERCONNECTING BOX (Test unit No 8)	Z4/6625-99-106-3532	1	Simulates vehicle harness
13	MONITOR POWER SUPPLY - (No 1, Test unit No 6)	Z4/6625-99-106-4948	1	Output metering for P.S.R.47
14	including - CASE EQPT, RACK MTG, 8 unit, 9 in. chassis Qty 1	Z1/5975-99-940-0538		
15	LID, Case eqpt, rack mtg, 8 unit Qty 1	Z1/5975-99-940-0542		

Table 4002 - (cont)

Item No	Designation	Catalogue No	No off	Remarks
16	(No 2, Test unit No 7)	Z4/6625-99-106-4949	1	Input metering for P.S.R.47
17	including - CASE EQPT, RACK MTG, 8 unit, 9 in.	Z1/5975-99-940-0538		
18	chassis Qty 1 LID, Case eqpt, rack mtg Qty 1	Z1/5975-99-940-0542		
19	REGULATOR, VOLTAGE, resistor type (Test unit No 13)	Z4/6625-99-106-3687	1	Completes heater circuit when amplifier is removed from case
20	SIMULATOR, RADIO SIGNAL (Test unit No 1)	Z4/6625-99-106-4661	1	Simulates r.f. output of T.R. C13.
21	including - CASE EQPT, RACK MTG, 8 unit, 9 in.	Z1/5975-99-940-0538		
22	chassis Qty 1 LID, Case eqpt, rack mtg, 8 unit Qty 1	Z1/5975-99-940-0542		
23	SWITCH, SUB-ASSEMBLY	Z4/6625-99-106-3531	1	Switches 24V supply to loading coil switch unit
24	SHIPPING AND STORAGE CONTAINER	-	1	
25	PLUG AND SOCKET ASSEMBLY, ELECTRICAL, two plugs, one socket  CABLE ASSEMBLY (Test unit No 11)	Z32/5935-99-106-4944	1	T junction. Connects 70 ohm load for cut-out tests.
26	RADIO FREQUENCY - UR57, 3 ft lg o/a ("d")	Z42/5995-99-106-4892	2	Burndept-Burndept termination
27	UR57, 3 ft lg o/a ("e")	Z42/5995-99-106-4891	2	Burndept-'N' type termination.
28	UR70, 4 ft lg o/a ("p")	Z42/5995-99-106-4886	2	E.H.T. cables
29	SPECIAL PURPOSE, ELECTRICAL - 3 conductors, 4 ft lg o/a ("o")	Z42/5995-99-106-4887	1	Thorn-Pygmy termination
30	12 conductors, 4 ft lg o/a ("a")	Z42/5995-99-106-4890	3	Mk 4, 12 way termination



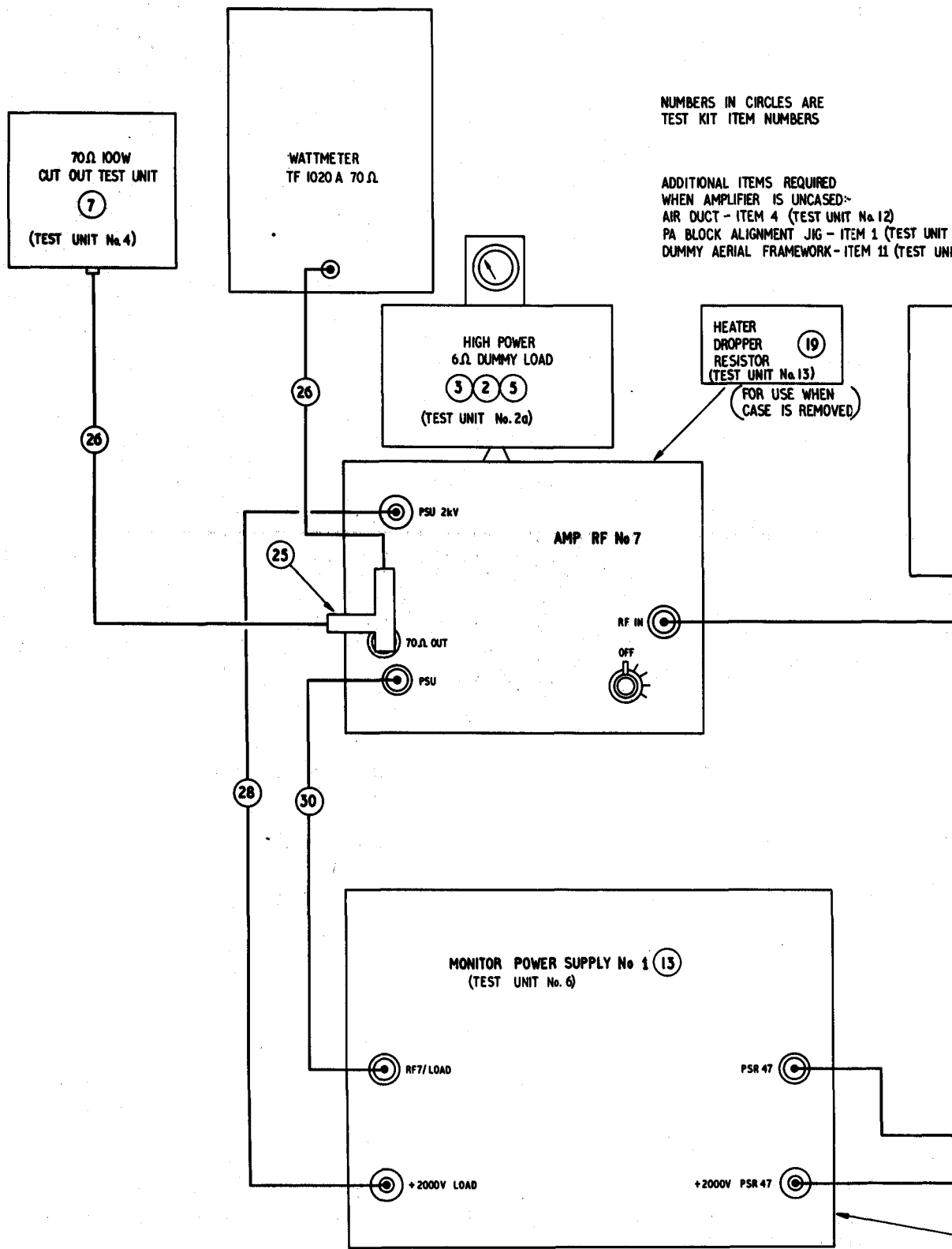

2304/70

Fig 4001 - Test equipment connection



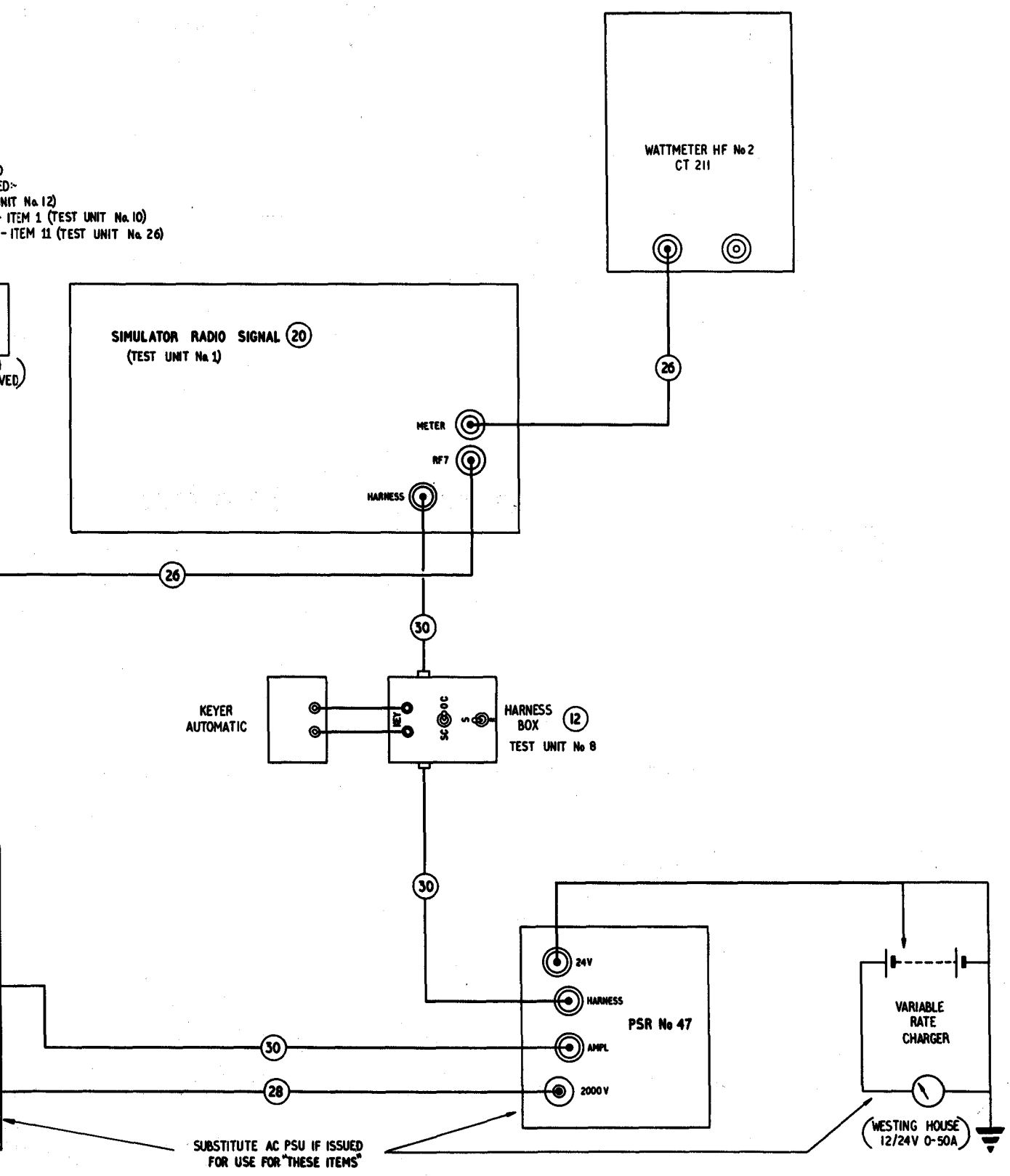

connections used with Amplifier, r.f. No 7



RESTRICTED

Fig 4001 - Test equipment connections used with Amplifier, r.f. No 7

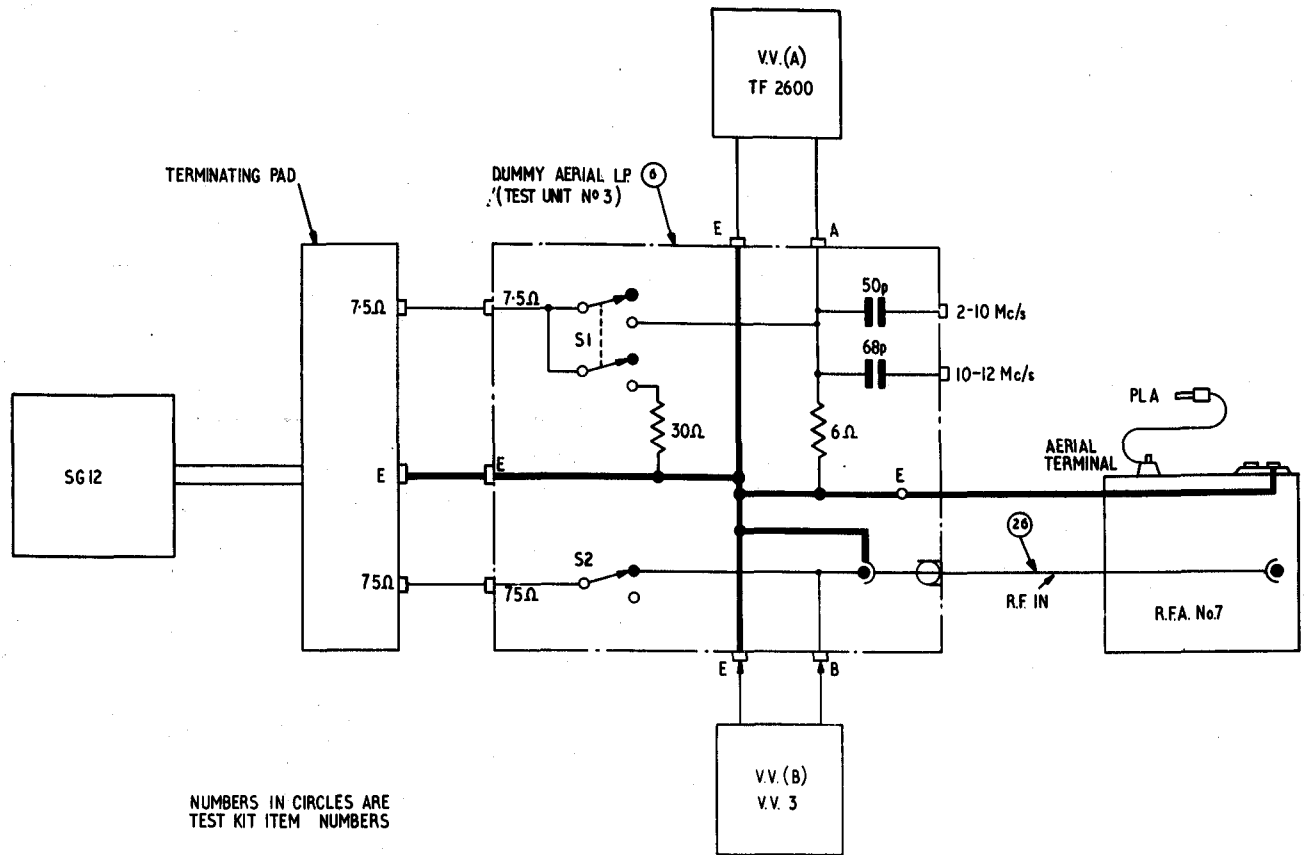

2384/40

Fig 4002 - Connections used with low power dummy aerial

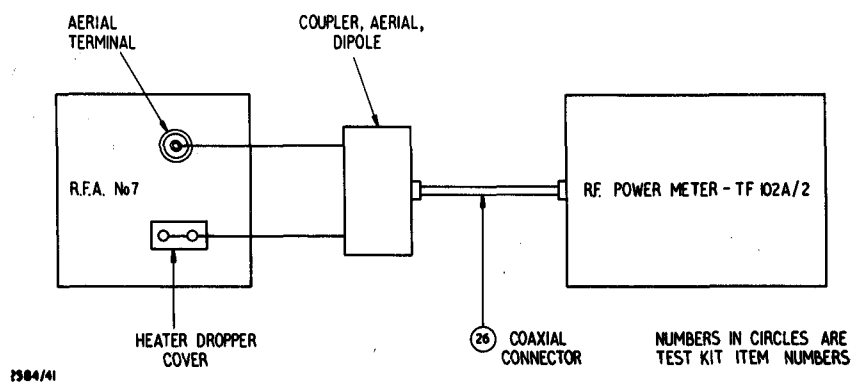

2384/41

Fig 4003 - Aerial coil minimum inductance test



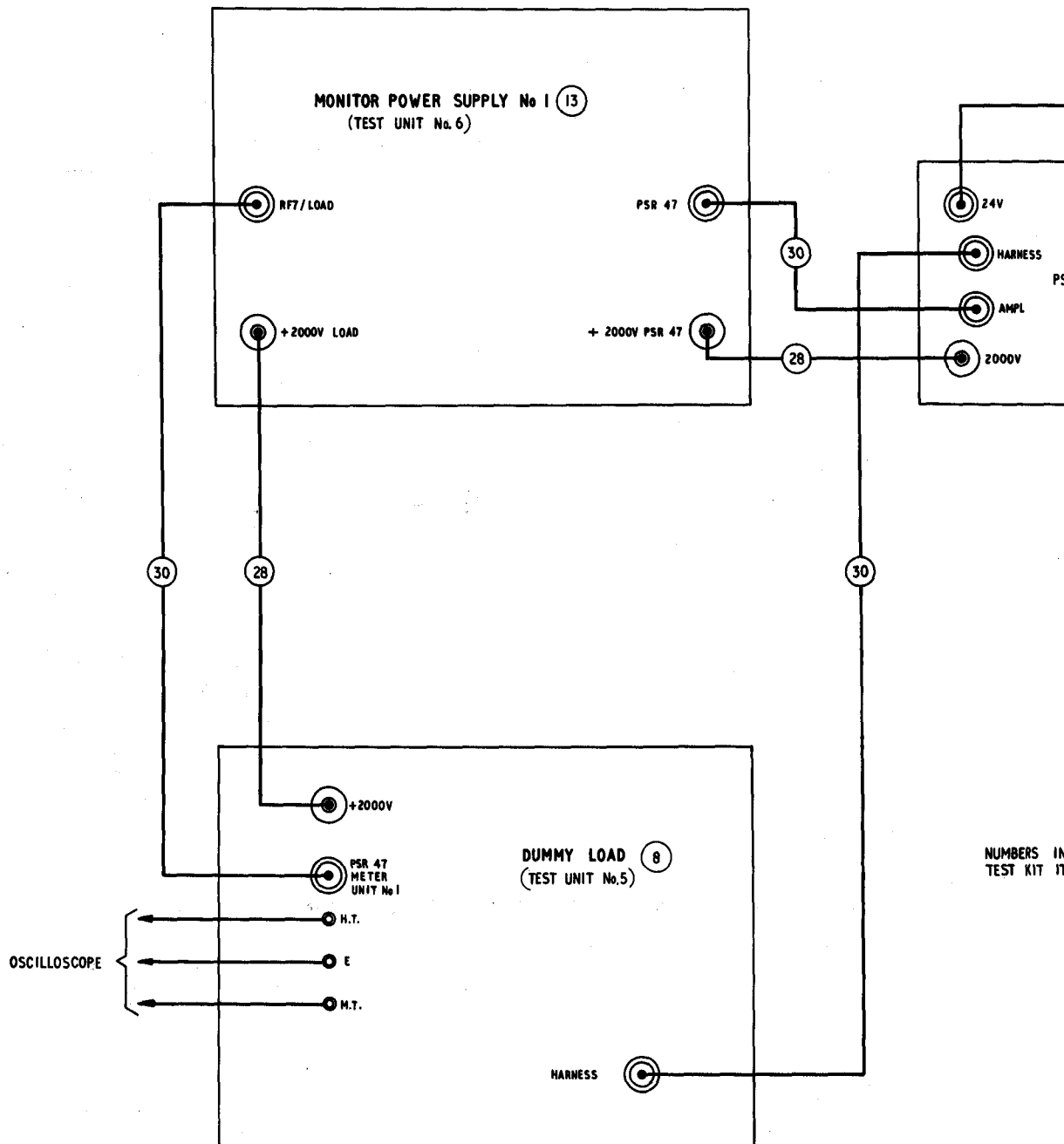

2594412

Fig 4004 - Connections for



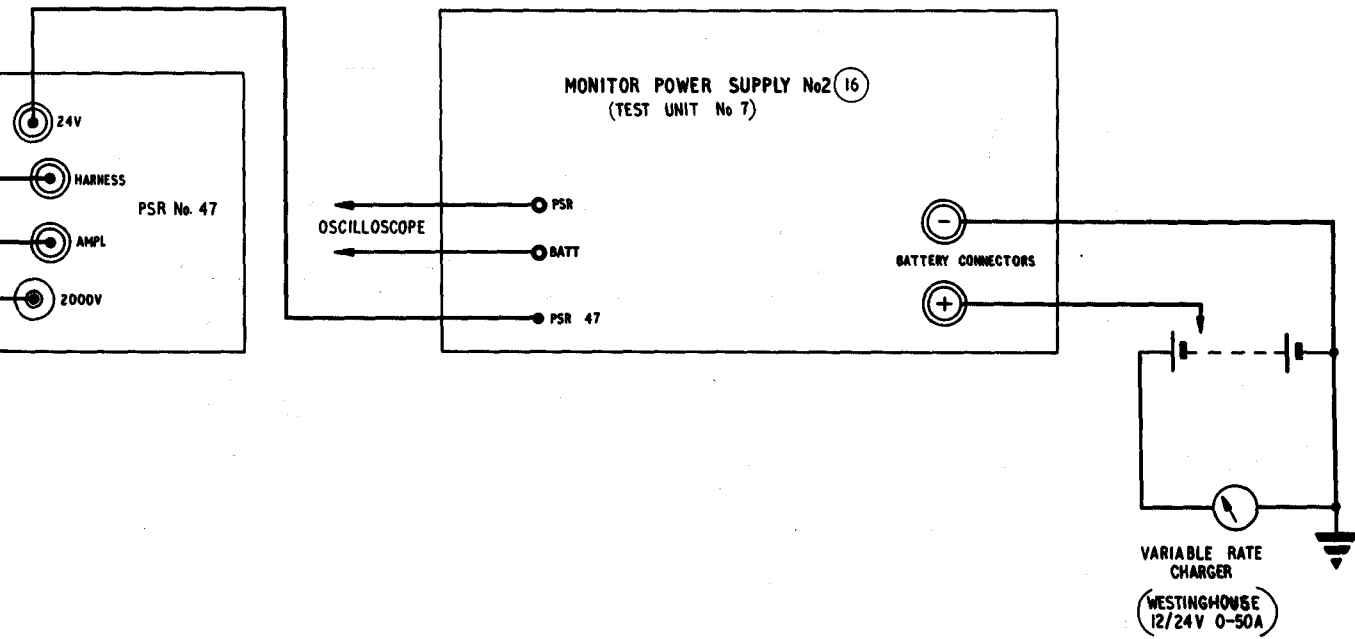

NUMBERS IN CIRCLES ARE  
TEST KIT ITEM NUMBERS

Directions for P.S.R. No 47 tests

RESTRICTED

Fig 4004 - Connections for P.S.R. No 47 tests

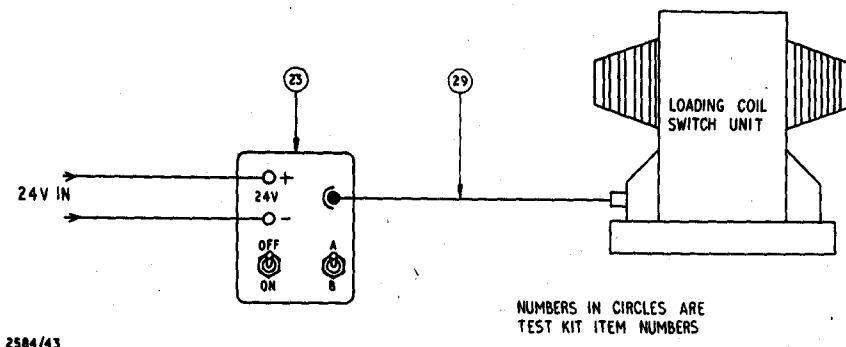

Fig 4005 - Loading coil switch tests

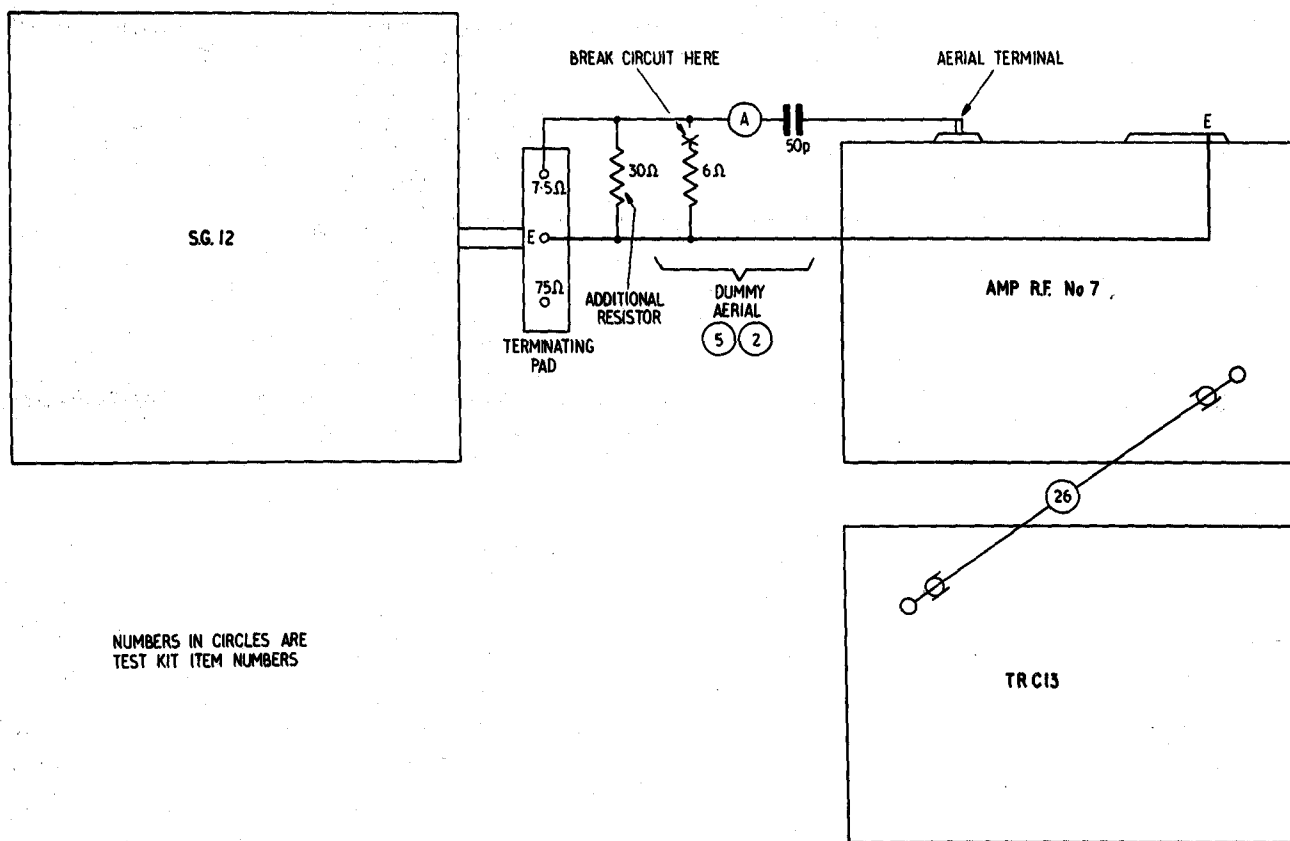

Fig 4006 - Fan motor interference with receiver





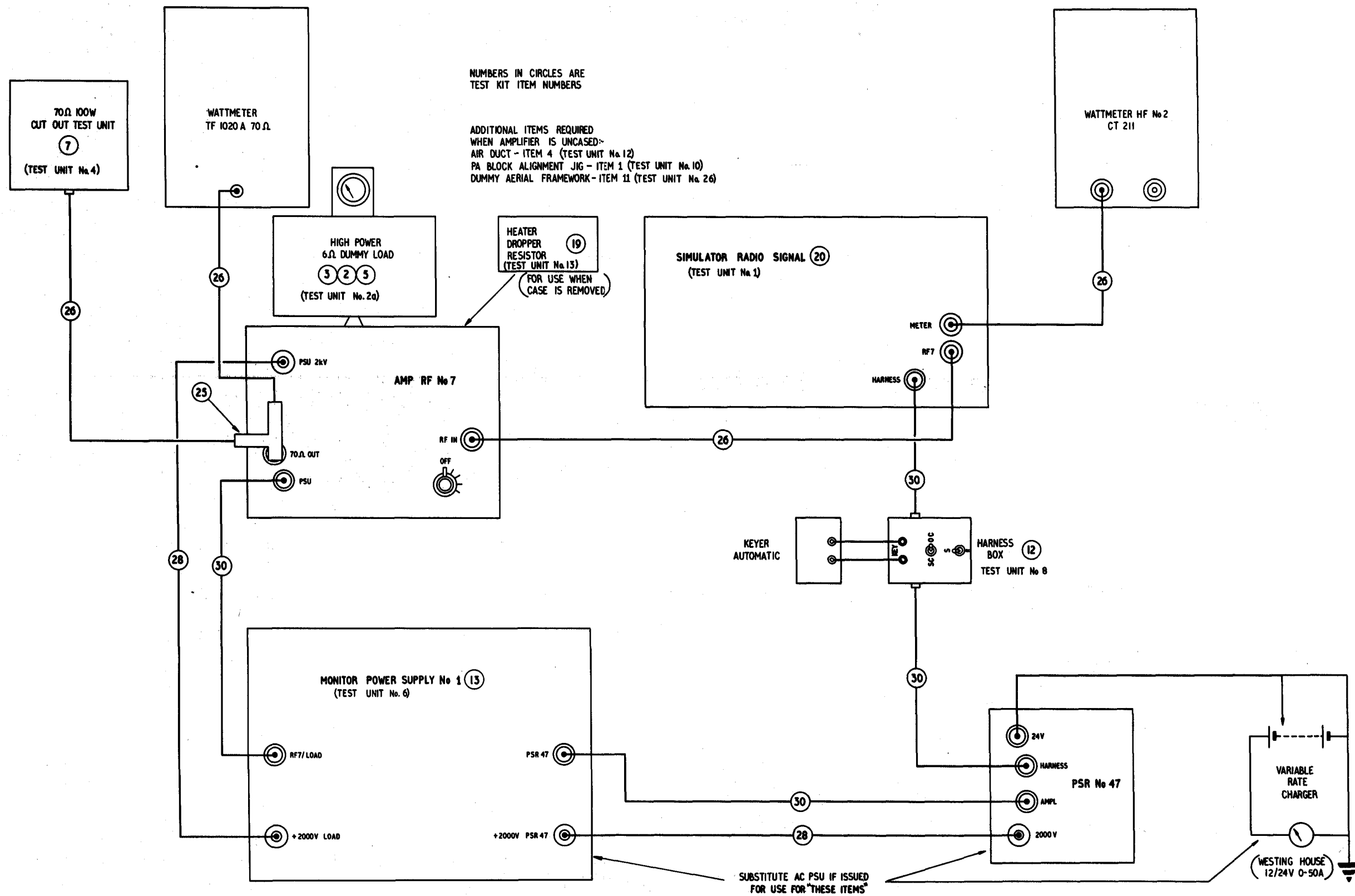

Fig 4001 - Test equipment connections used with Amplifier, r.f. No 7

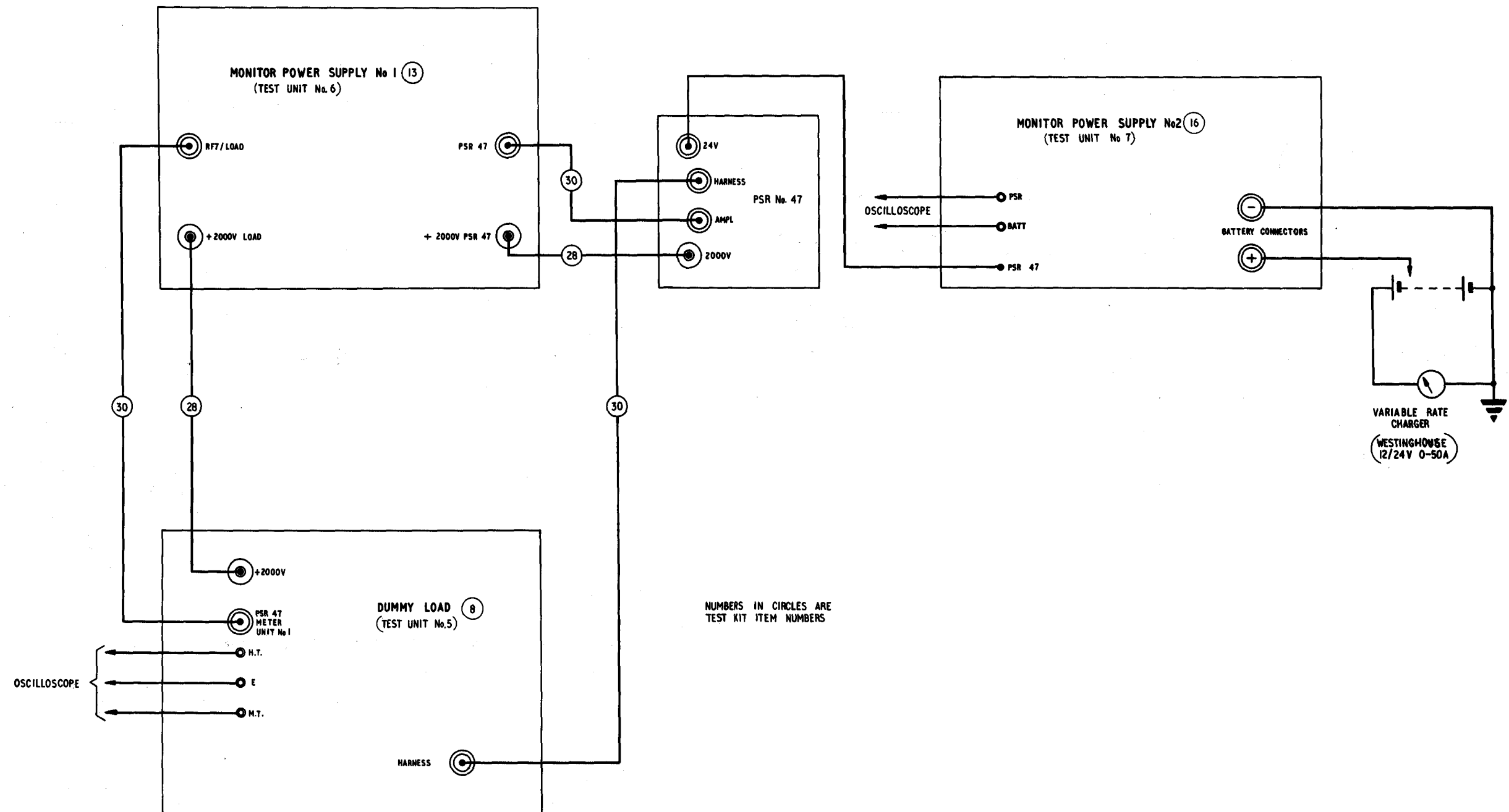

Fig 4004 - Connections for P.S.R. No 47 tests